

**Concept-Development Practice Page** **2-1**

**Static Equilibrium**

1. Little Nellie Newton wishes to be a gymnast and hangs from a variety of positions as shown. Since she is not accelerating, the net force on her is zero. That is,  $\Sigma F = 0$ . This means the upward pull of the rope(s) equals the downward pull of gravity. She weighs 300 N. Show the scale reading(s) for each case.

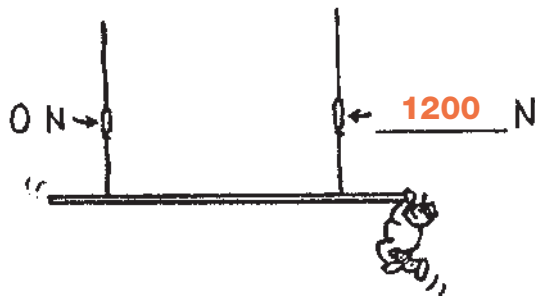
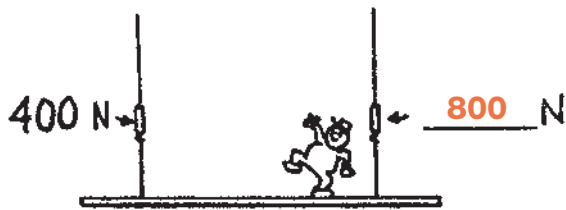
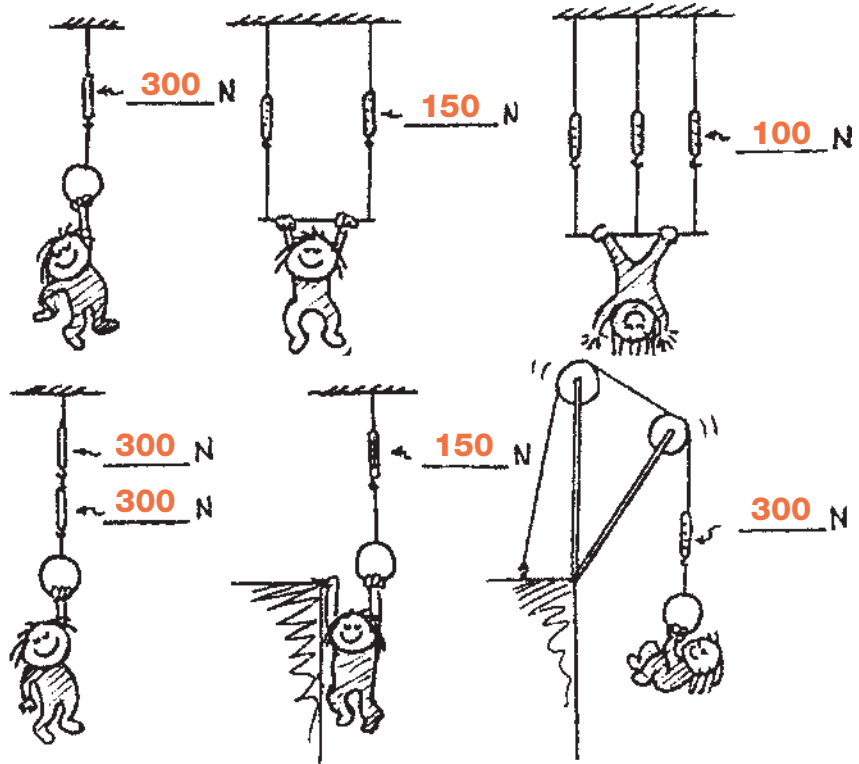

- When Burl the painter stands in the exact middle of his staging, the left scale reads 600 N. Fill in the reading on the right scale. The total weight of Burl and staging must be **1200** N.
- Burl stands farther from the left. Fill in the reading on the right scale.
- In a silly mood, Burl dangles from the right end. Fill in the reading on the right scale.

© Pearson Education, Inc., or its affiliate(s). All rights reserved.

**The Equilibrium Rule:  $\Sigma F = 0$**

1. Manuel weighs 1000 N and stands in the middle of a board that weighs 200 N. The ends of the board rest on bathroom scales. (We can assume the weight of the board acts at its center.) Fill in the correct weight reading on each scale.

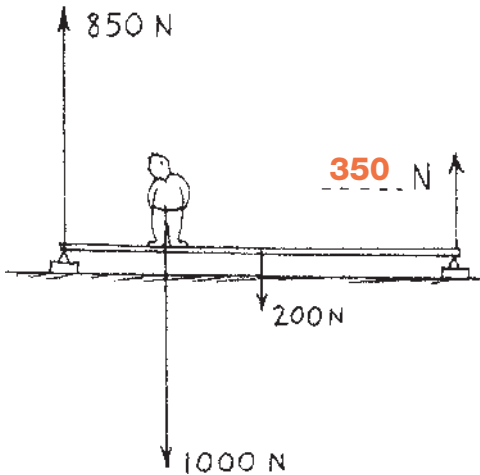
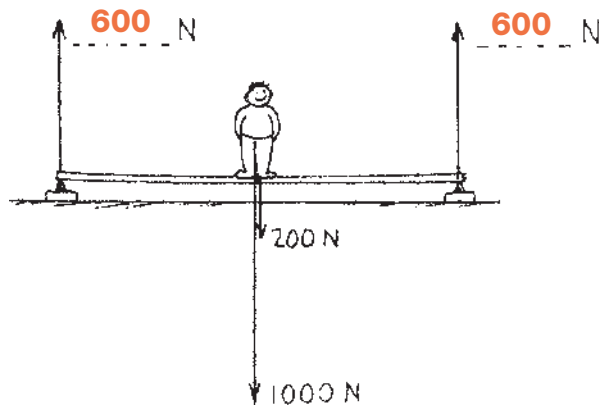

2. When Manuel moves to the left as shown, the scale closest to him reads 850 N. Fill in the weight for the far scale.

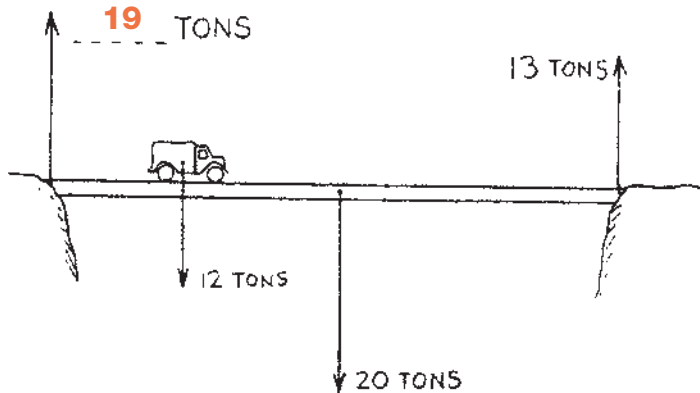

3. A 12-ton truck is one-quarter the way across a bridge that weighs 20 tons. A 13-ton force supports the right side of the bridge as shown. How much support force is on the left side?

4. A 1000-N crate resting on a surface is connected to a 500-N block through a frictionless pulley as shown. Friction between the crate and surface is enough to keep the system at rest. The arrows show the forces that act on the crate and the block. Fill in the magnitude of each force.

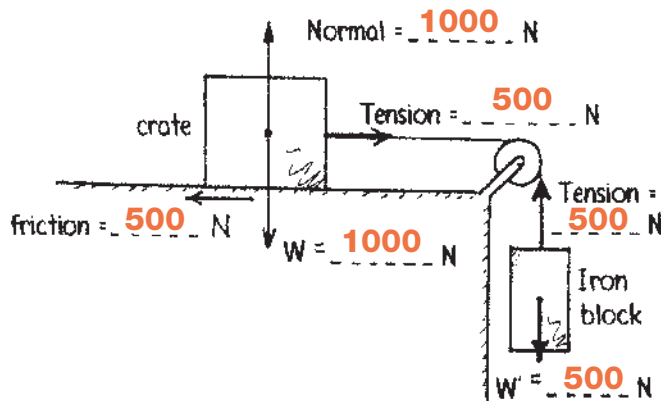

5. If the crate and block in the preceding question move at constant speed, the tension in the rope (is the same) (increases) (decreases).  
The sliding system is then in (static equilibrium) (dynamic equilibrium).

**CONCEPTUAL PHYSICS**