

Teacher Version

Geo BMK 1 Review

Directions: Please choose the best answer choice for each of the following questions.

1. The tip of a pendulum at rest sits at point B . During an experiment, a physics student sets the pendulum in motion. The tip of the pendulum swings back and forth along part of a circular path from point A to point C . During each swing the tip passes through point B . Name all the angles in the diagram.

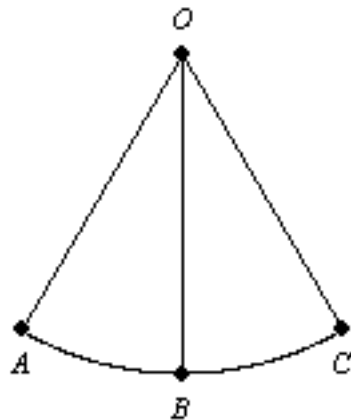

- A. $\angle AOB, \angle BOC$
- B. $\angle AOB, \angle COB, \angle AOC$
- C. $\angle AOB, \angle BOA, \angle COB, \angle BOC$
- D. $\angle OAB, \angle OBC, \angle OCB$

ItemID DD-HOLT.1037256
Correct B
Standard(s) MA.8-12.G.1.0 (8, 9, 10, 11, 12)

2. Find the length of \overline{BC} .

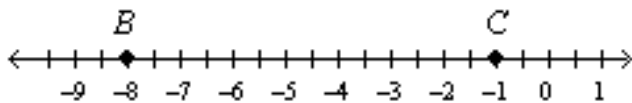

- A. $BC = -7$
- B. $BC = -9$
- C. $BC = 7$
- D. $BC = 8$

ItemID DD-HOLT.1037251
Correct C

Standard(s) MA.8-12.G.1.0 (8, 9, 10, 11, 12)

3. Draw and label a pair of opposite rays \overrightarrow{FG} and \overrightarrow{FH} .

A.



B.

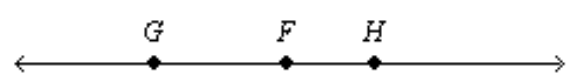

C.



D.

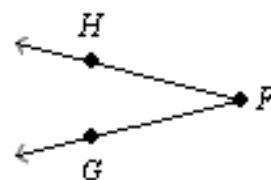

ItemID DD-HOLT.1037248
Correct B
Standard(s) MA.8-12.G.1.0 (8, 9, 10, 11, 12)

4. The map shows a linear section of Highway 35. Today, the Ybarras plan to drive the 360 miles from Springfield to Junction City. They will stop for lunch in Roseburg, which is at the midpoint of the trip. If they have already traveled 55 miles this morning, how much farther must they travel before they stop for lunch?

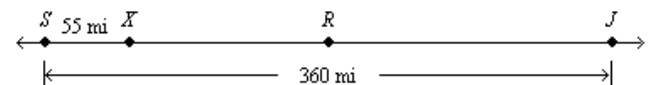

- A. 125 mi
- B. 145 mi
- C. 180 mi

Go on to the next page »

D. 305 mi

ItemID DD-HOLT.1037254

Correct A

Standard(s) MA.8-12.G.1.0 (8, 9, 10, 11, 12)

5. D is between C and E . $CE = 6x$, $CD = 4x + 8$, and $DE = 27$. Find CE .

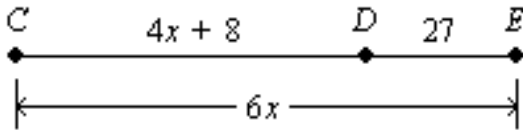

- A. $CE = 17.5$
 B. $CE = 78$
 C. $CE = 105$
 D. $CE = 57$

ItemID DD-HOLT.1037253

Correct C

Standard(s) MA.8-12.G.1.0 (8, 9, 10, 11, 12)

6. Name three collinear points.

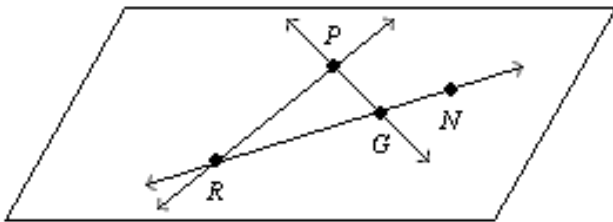

- A. $P, G,$ and N
 B. $R, P,$ and N
 C. $R, P,$ and G
 D. $R, G,$ and N

ItemID DD-HOLT.1037247

Correct D

Standard(s) MA.8-12.G.1.0 (8, 9, 10, 11, 12)

7. \overrightarrow{BD} bisects $\angle ABC$, $m\angle ABD = (7x - 1)^\circ$, and $m\angle DBC = (4x + 8)^\circ$. Find $m\angle ABD$.

- A. $m\angle ABD = 22^\circ$
 B. $m\angle ABD = 3^\circ$

C. $m\angle ABD = 40^\circ$

D. $m\angle ABD = 20^\circ$

ItemID DD-HOLT.1037259

Correct D

Standard(s) MA.8-12.G.1.0 (8, 9, 10, 11, 12)

8. What conclusion can be made using the statements below?

If it rains today, Margo will stay inside. If Margo stays inside today, she will finish her book. It rained today.

- A. Margo went outside.
 B. Margo finished her book.
 C. Margo will stay inside tomorrow.
 D. Margo will finish her book tomorrow.

ItemID DD.1000940

Correct B

Standard(s) MA.8-12.G.1.0 (8, 9, 10, 11, 12)

9. $m\angle IJK = 57^\circ$ and $m\angle IJL = 20^\circ$. Find $m\angle LJK$.

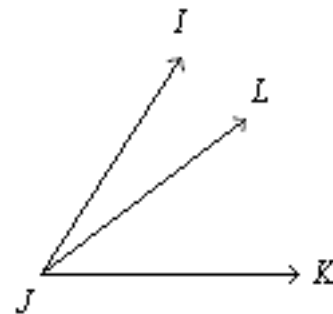

- A. $m\angle LJK = -37^\circ$
 B. $m\angle LJK = 77^\circ$
 C. $m\angle LJK = 37^\circ$
 D. $m\angle LJK = 40^\circ$

ItemID DD-HOLT.1037258

Go on to the next page »

Correct C
Standard(s) MA.8-12.G.1.0 (8, 9, 10, 11, 12)

10. Find the next item in the pattern 2, 3, 5, 7, 11, ...
- A. 13
 - B. 12
 - C. 15
 - D. 17

ItemID DD-HOLT.1037282
Correct A
Standard(s) MA.8-12.G.1.0 (8, 9, 10, 11, 12)

11. Name two lines in the figure.

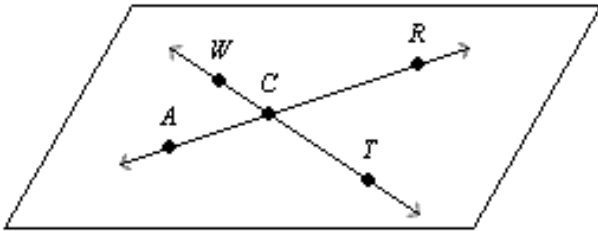

- A. A and T
- B. WCR and TRA
- C. \overleftrightarrow{WC} and \overleftrightarrow{CR}
- D. \overleftrightarrow{WC} and \overleftrightarrow{WT}

ItemID DD-HOLT.1037246
Correct C
Standard(s) MA.8-12.G.1.0 (8, 9, 10, 11, 12)

12. Which is an example of an undefined term?
- A. square
 - B. line
 - C. parallel lines
 - D. sphere

ItemID DD.1000943
Correct B
Standard(s) MA.8-12.G.1.0 (8, 9, 10, 11, 12)

13. Use the Law of Syllogism to draw a conclusion from the given information.

Given: If two lines are perpendicular, then they form right angles. If two lines meet at a 90° angle, then they are perpendicular. Two lines meet at a 90° angle.

- A. Conclusion : The lines are parallel.
- B. Conclusion : The lines are perpendicular and meet at a 90° angle.
- C. Conclusion : The lines meet at a 90° angle.
- D. Conclusion : The lines form a right angle.

ItemID DD-HOLT.1037295
Correct D
Standard(s) MA.8-12.G.1.0 (8, 9, 10, 11, 12)

14. Complete the conjecture.
 The sum of two odd numbers is ____.
- A. even
 - B. odd
 - C. sometimes odd, sometimes even
 - D. even most of the time

ItemID DD-HOLT.1037283
Correct A
Standard(s) MA.8-12.G.1.0 (8, 9, 10, 11, 12)

15. Which of the following is a statement that can be proven?
- A. axiom
 - B. given
 - C. theorem
 - D. undefined term

ItemID DD.1000942
Correct C
Standard(s) MA.8-12.G.1.0 (8, 9, 10, 11, 12)

16. Which of the following is the intersection of two distinct lines?
- A. an angle
 - B. a line
 - C. a plane
 - D. a point

ItemID DD.1000805
Correct D

Go on to the next page »

Standard(s) MA.8-12.G.1.0 (8, 9, 10, 11, 12)

17. The radius of $\odot A$ is multiplied by $\frac{1}{3}$. Describe the effect of the change on the area.

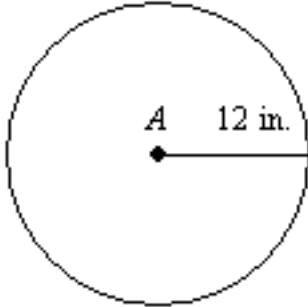

- A. The area is multiplied by 3 .
 B. The area is multiplied by $(\frac{1}{3})^2$.
 C. There is no effect on the area.
 D. The area is multiplied by $\frac{1}{3}$.

ItemID DD-HOLT.1037504

Correct B

Standard(s) MA.8-12.G.11.0 (8, 9, 10, 11, 12)

18. On a sketch of a mural, 3 inches represents one foot in the mural. A door in the sketch is 2 inches wide by 5 inches high. What is the perimeter of the door in the mural expressed in inches?

- A. 4 in.
 B. 8 in.
 C. 20 in.
 D. 56 in.

ItemID DD-HOLT.1037612

Correct D

Standard(s) MA.8-12.G.11.0 (8, 9, 10, 11, 12)

19. Tina has two rectangular rooms in her house. Her living room is three times as wide and four times as long as her bedroom. What is the relationship of the area of Tina's living room to her bedroom?

- A. Three times as great
 B. Four times as great

- C. Seven times as great
 D. Twelve times as great

ItemID DD.1000855

Correct D

Standard(s) MA.8-12.G.11.0 (8, 9, 10, 11, 12)

20. John has two square decks on his house. The sides of Deck 1 are twice as long as the sides of Deck 2. If one side of Deck 2 measures d ft. what is the perimeter of Deck 1?

- A. $4d$ ft.
 B. $8d$ ft.
 C. d^2 ft.²
 D. $4d^2$ ft.²

ItemID DD.1000854

Correct B

Standard(s) MA.8-12.G.11.0 (8, 9, 10, 11, 12)

21. Steven is using a straightedge and compass to complete the construction below.

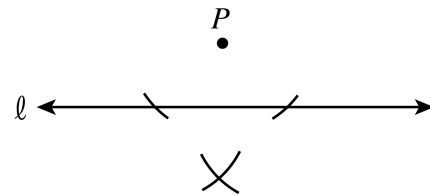

What is Steven constructing?

- A. A line perpendicular to ℓ through P.
 B. A perpendicular bisector of ℓ .
 C. A line parallel to ℓ through P.
 D. A line parallel to P through ℓ .

ItemID DD.1000875

Correct A

Standard(s) MA.8-12.G.16.0 (8, 9, 10, 11, 12)

22. P is the midpoint of \overline{LM} . If the coordinates of L are $(-2, 5)$ and the coordinates of P are $(0, 1)$, what are the coordinates of M?

- A. $(-2, 3)$
 B. $(-1, 3)$
 C. $(2, -3)$

Go on to the next page »

D. (2, -5)

ItemID DD.1000924

Correct C

Standard(s) MA.8-12.G.17.0 (8, 9, 10, 11, 12)

23. Sarah is plotting her house and her friend Angela's house on a grid. Sara's house is at (4, 7) and Angela's house is at (2, 3). How far apart, on the grid, are the houses?

A. $\sqrt{6}$

B. 4

C. $2\sqrt{5}$

D. $2\sqrt{34}$

ItemID DD.1000923

Correct C

Standard(s) MA.8-12.G.17.0 (8, 9, 10, 11, 12)

24.

Find the coordinates of the midpoint of \overline{CM} with endpoints C (1, -6) and M (7, 5).

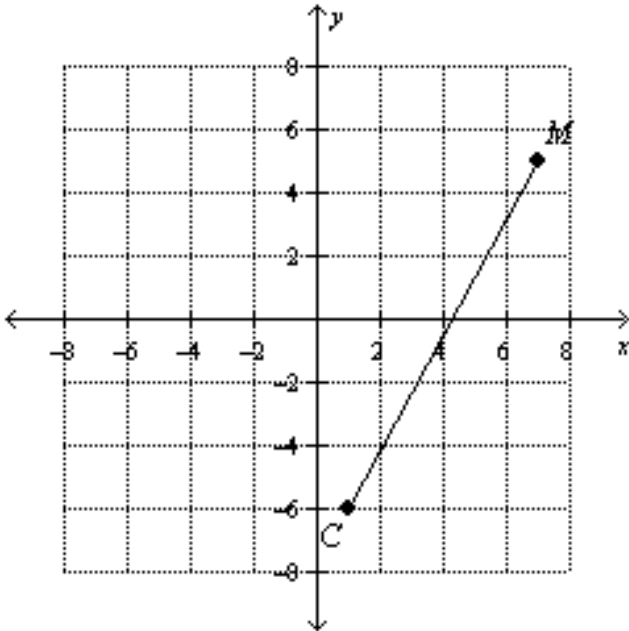

A. (3, -1)

B. (8, -1)

C. $(4, -\frac{1}{2})$

D. $(4\frac{1}{2}, \frac{1}{2})$

ItemID DD-HOLT.1037272

Correct C

Standard(s) MA.8-12.G.17.0 (8, 9, 10, 11, 12)

25.

M is the midpoint of \overline{AN} , A has coordinates (-6, -6), and M has coordinates (1, 2). Find the coordinates of N.

A. (8, 10)

B. (-5, -4)

C. $(-2\frac{1}{2}, -2)$

D. $(8\frac{1}{2}, 9\frac{1}{2})$

ItemID DD-HOLT.1037273

Correct A

Standard(s) MA.8-12.G.17.0 (8, 9, 10, 11, 12)

26. Circle C has a diameter \overline{GH} . If G is at (-1, 5) and H is at (5, -2), what is the length of the radius of circle C?

A. $2\frac{1}{2}$

B. $\frac{1}{2}\sqrt{85}$

C. 5

D. $\sqrt{85}$

ItemID DD.1000922

Correct C

Standard(s) MA.8-12.G.17.0 (8, 9, 10, 11, 12)

Go on to the next page »

27. What is the equation of the line on the graph

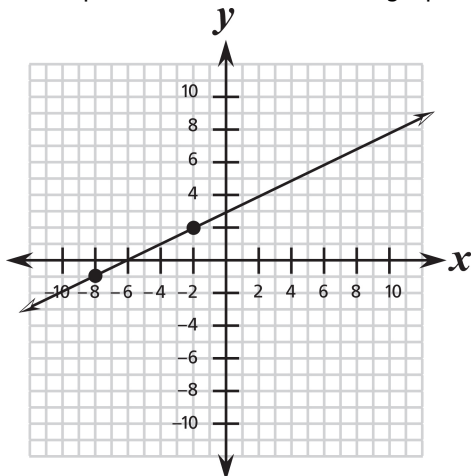

below?

- A. $y = \frac{1}{2}x + 3$
- B. $y = -\frac{1}{2}x + 3$
- C. $y = 2x + 3$
- D. $y = -2x + 3$

ItemID DD.1000901
Correct A
Standard(s) MA.8-12.G.17.0 (8, 9, 10, 11, 12)

28. Write the converse, inverse, and contrapositive of the conditional statement.

If an animal is a bird, then it has two eyes.

- A. Converse: If an animal is not a bird, then it does not have two eyes.
 Inverse: If an animal does not have two eyes, then it is not a bird.
 Contrapositive: If an animal is a bird, then it has two eyes.
- B. Converse: If an animal has two eyes, then it is a bird.
 Inverse: If an animal is not a bird, then it does not have two eyes.
 Contrapositive: If an animal does not have two eyes, then it is not a bird.
- C. Converse: If an animal does not have two eyes, then it is not a bird.
 Inverse: If an animal is not a bird, then it does not have two eyes.
 Contrapositive: If an animal has two eyes, then it is a bird.
- D. Converse: All birds have two eyes.
 Inverse: All animals have two eyes.

Contrapositive: All birds are animals, and animals have two eyes.

ItemID DD-HOLT.1037290
Correct B
Standard(s) MA.8-12.G.3.0 (8, 9, 10, 11, 12)

29. Determine if the conditional statement is true. If false, give a counterexample. If a figure has four sides, then it is a square.

- A. True.
- B. False; A rectangle has four sides, and it is not a square.

ItemID DD-HOLT.1037289
Correct B
Standard(s) MA.8-12.G.3.0 (8, 9, 10, 11, 12)

30. Write a conditional statement from the statement. A horse has 4 legs.

- A. If it has 4 legs then it is a horse.
- B. Every horse has 4 legs.
- C. If it is a horse then it has 4 legs.
- D. It has 4 legs and it is a horse.

ItemID DD-HOLT.1037288
Correct C
Standard(s) MA.8-12.G.3.0 (8, 9, 10, 11, 12)

31. Determine if the conjecture is valid by the Law of Detachment.

Given : If Tommy makes cookies tonight, then Tommy must have an oven. Tommy has an oven.
 Conjecture : Tommy made cookies tonight.

- A. The conjecture is valid, because if Tommy didn't have an oven then he didn't make cookies tonight
- B. The conjecture is not valid, because if Tommy didn't have an oven then he didn't make cookies tonight.
- C. The conjecture is valid, because Tommy could have an oven but he could make something besides cookies tonight.
- D. The conjecture is not valid, because Tommy could have an oven but he could make something besides cookies tonight.

ItemID DD-HOLT.1037293
Correct D

Go on to the next page »

Standard(s) MA.8-12.G.3.0 (8, 9, 10, 11, 12)

32. Write the conditional statement and converse within the biconditional.
A rectangle is a square if and only if all four sides of the rectangle have equal lengths.
- A. Conditional: If all four sides of the rectangle have equal lengths, then it is a square.
Converse: If a rectangle is a square, then its four sides have equal lengths.
- B. Conditional: If a rectangle is a square, then it is also a rhombus.
Converse: If a rectangle is a rhombus, then it is also a square.
- C. Conditional: If all four sides have equal lengths, then all four angles are 90° .
Converse: If all four angles are 90° , then all four sides have equal lengths.
- D. Conditional: If a rectangle is not a square, then its sides are of different lengths.
Converse: If the sides are of different lengths, then the rectangle is not a square.

ItemID DD-HOLT.1037297

Correct A

Standard(s) MA.8-12.G.3.0 (8, 9, 10, 11, 12)

33. Determine if the conjecture is valid by the Law of Syllogism.
Given : If you are in California, then you are in the west coast. If you are in Los Angeles, then you are in California.
Conjecture : If you are in Los Angeles, then you are in the west coast.
- A. No, the conjecture is not valid.
- B. Yes, the conjecture is valid.

ItemID DD-HOLT.1037294

Correct B

Standard(s) MA.8-12.G.3.0 (8, 9, 10, 11, 12)

34. Determine if the biconditional is true. If false, give a counterexample.
A figure is a square if and only if it is a rectangle.
- A. The biconditional is true.
- B. The biconditional is false. A rectangle does not necessarily have four congruent sides.

- C. The biconditional is false. All squares are parallelograms with four 90° angles.
- D. The biconditional is false. A rectangle does not necessarily have four 90° angles.

ItemID DD-HOLT.1037299

Correct B

Standard(s) MA.8-12.G.3.0 (8, 9, 10, 11, 12)

35. Christine knows that if a number is divisible by 12, then the number is also divisible by the factors of 12. Using this information, Christine made the conclusion below.

Given: The number of students in Christine's school is divisible by 12.

Conclusion: The number of students in Christine's school is also divisible by 8. Is Christine's conclusion valid, and why?

- A. Yes, because 8 is a factor of 12.
- B. No, because no number is divisible by 8.
- C. No, because 8 is not a factor of 12.
- D. There is not enough information given.

ItemID DD.1000812

Correct C

Standard(s) MA.8-12.G.3.0 (8, 9, 10, 11, 12)

36. Jack made the statement below. $x^2 \geq \frac{x}{2}$ for all real numbers x . Which of the following can be used as a counter example?
- A. $x = -4$
- B. $x = 1$
- C. $x = \frac{1}{4}$
- D. $x = 4$

ItemID DD.1000813

Correct C

Standard(s) MA.8-12.G.3.0 (8, 9, 10, 11, 12)

37. Write the definition as a biconditional.
An acute angle is an angle whose measure is less than 90° .

Go on to the next page »

- A. An angle is acute if its measure is less than 90° .
- B. An angle is acute if and only if its measure is less than 90° .
- C. An angle's measure is less than 90° if it is acute.
- D. An angle is acute if and only if it is not obtuse.

ItemID DD-HOLT.1037300
Correct B
Standard(s) MA.8-12.G.3.0 (8, 9, 10, 11, 12)

38. Show that the conjecture is false by finding a counterexample.

If $a > b$, then $\frac{a}{b} > 0$.

- A. $a = 11, b = -3$
- B. $a = 11, b = 3$
- C. $a = 3, b = 11$
- D. $a = -11, b = 3$

ItemID DD-HOLT.1037285
Correct A
Standard(s) MA.8-12.G.3.0 (8, 9, 10, 11, 12)

39. What is the truth value of the biconditional formed from the conditional, "If B is the midpoint of A and C , then $\overline{AB} = \overline{BC}$." Explain.

- A. The conditional is true.
 The converse, "If $\overline{AB} = \overline{BC}$ then B is the midpoint of \overline{AC} " is false.
 Since the conditional is true but the converse is false, the biconditional is false.
- B. The conditional is true.
 The converse, "If $\overline{AB} = \overline{BC}$ then B is the midpoint of \overline{AC} " is true.
 Since the conditional is true and the converse is true, the biconditional is true.
- C. The conditional is false.

The converse, "If $\overline{AB} = \overline{BC}$ then B is the midpoint of \overline{AC} " is false.
 Since the conditional is false and the converse is false, the biconditional is true.

- D. The conditional is false.
 The converse, "If $\overline{AB} = \overline{BC}$ then B is the midpoint of \overline{AC} " is true.
 Since the conditional is false and the converse is true, the biconditional is false.

ItemID DD-HOLT.1037301
Correct A
Standard(s) MA.8-12.G.3.0 (8, 9, 10, 11, 12)

40. Marlon thinks he discovered a divisibility rule for 4. His rule states, "If you take an even number and multiply it by 100, then subtract the original number, the result is always divisible by 4. Which of the following numbers is a counterexample for Marlon's rule?"

- A. 2
- B. 4
- C. 8
- D. 12

ItemID DD.1000811
Correct A
Standard(s) MA.8-12.G.3.0 (8, 9, 10, 11, 12)

41. Identify a pair of parallel segments.

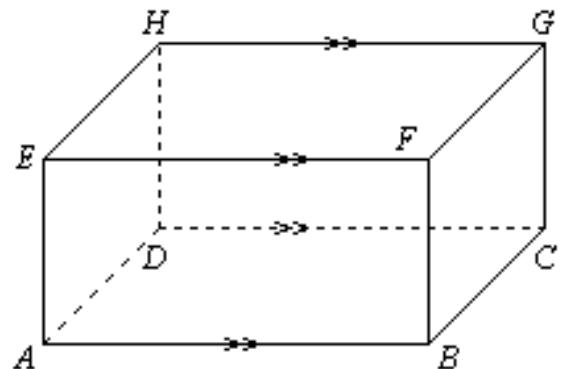

- A. $\overline{AB} \parallel \overline{EH}$
- B. $\overline{FB} \parallel \overline{AB}$

Go on to the next page »

C. $\overline{AB} \parallel \overline{HG}$

D. $\overline{DH} \parallel \overline{FG}$

ItemID DD-HOLT.1037314

Correct C

Standard(s) MA.8-12.G.7.0 (8, 9, 10, 11, 12)

42. Draw two lines and a transversal such that $\angle 1$ and $\angle 2$ are alternate interior angles, $\angle 2$ and $\angle 3$ are corresponding angles, and $\angle 3$ and $\angle 4$ are alternate exterior angles. What type of angle pair is $\angle 1$ and $\angle 4$?

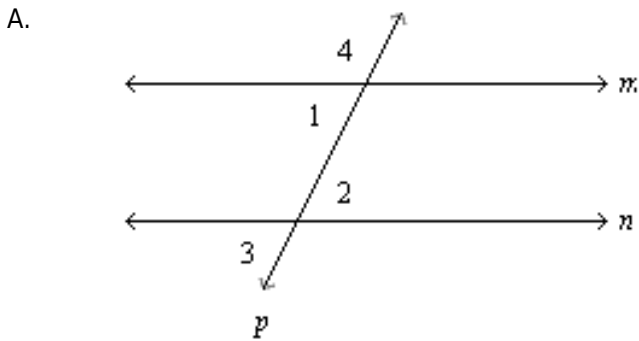

$\angle 1$ and $\angle 4$ are supplementary angles.

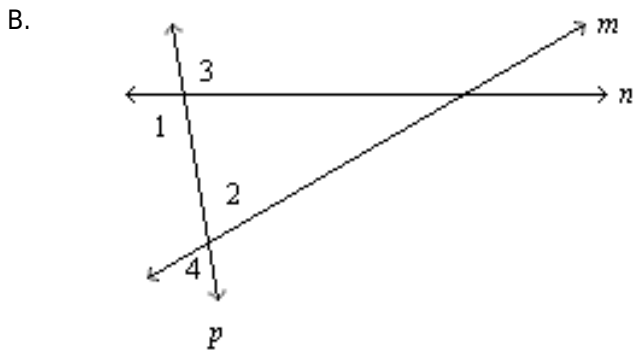

$\angle 1$ and $\angle 4$ are corresponding angles.

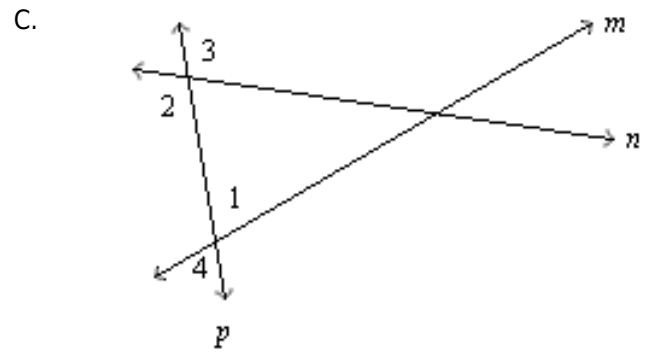

$\angle 1$ and $\angle 4$ are vertical angles.

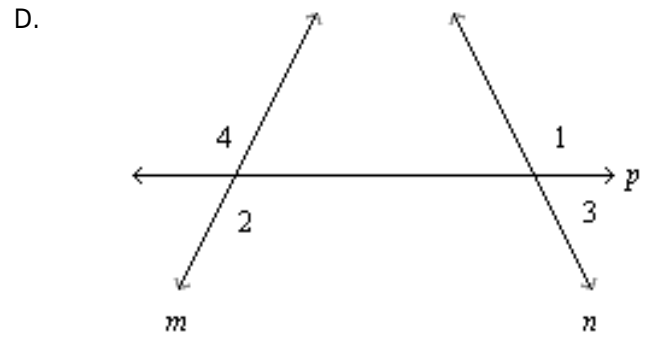

$\angle 1$ and $\angle 4$ are alternate exterior angles.

ItemID DD-HOLT.1037317

Correct B

Standard(s) MA.8-12.G.7.0 (8, 9, 10, 11, 12)

43. Find $m\angle ABC$.

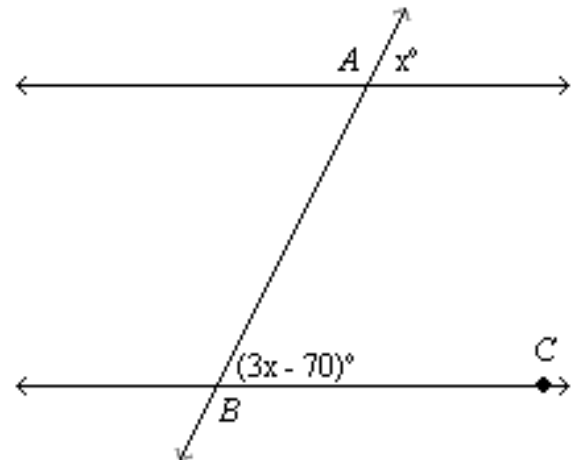

A. $m\angle ABC = 40^\circ$

B. $m\angle ABC = 45^\circ$

Go on to the next page »

- C. $m\angle ABC = 35^\circ$
 D. $m\angle ABC = 50^\circ$

ItemID DD-HOLT.1037318
Correct C
Standard(s) MA.8-12.G.7.0 (8, 9, 10, 11, 12)

44. Identify the transversal and classify the angle pair $\angle 11$ and $\angle 7$.

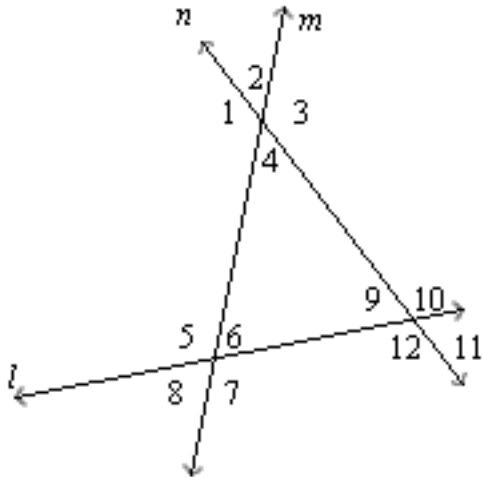

- A. The transversal is line l . The angles are corresponding angles.
 B. The transversal is line l . The angles are alternate interior angles.
 C. The transversal is line n . The angles are alternate exterior angles.
 D. The transversal is line m . The angles are corresponding angles.

ItemID DD-HOLT.1037316
Correct A
Standard(s) MA.8-12.G.7.0 (8, 9, 10, 11, 12)

45. Give an example of corresponding angles.

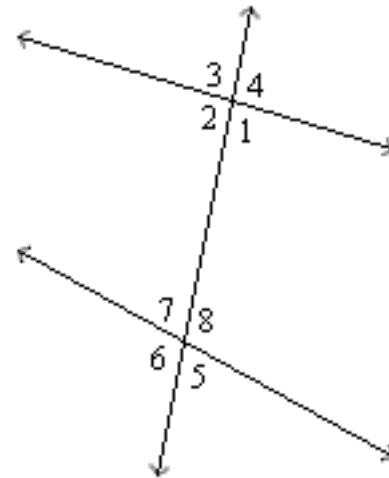

- A. $\angle 8$ and $\angle 4$
 B. $\angle 4$ and $\angle 1$
 C. $\angle 3$ and $\angle 6$
 D. $\angle 5$ and $\angle 7$

ItemID DD-HOLT.1037315
Correct A
Standard(s) MA.8-12.G.7.0 (8, 9, 10, 11, 12)

46. Use the Converse of the Corresponding Angles Postulate and $\angle 1 \cong \angle 2$ to show that $l \parallel m$.

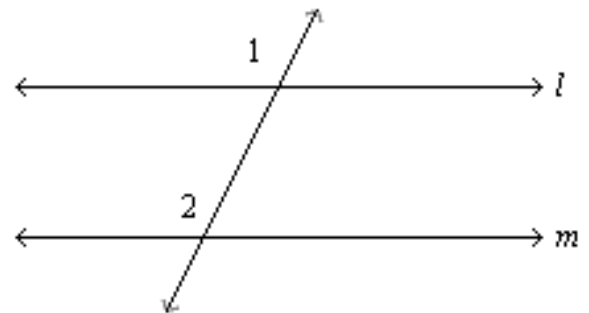

- A. $\angle 1 \cong \angle 2$ is given. From the diagram, $\angle 1$ and $\angle 2$ are alternate interior angles. So by the Converse of the Alternate Interior Angles Postulate, $l \parallel m$.
 B. $\angle 1 \cong \angle 2$ is given. From the diagram, $\angle 1$ and $\angle 2$ are corresponding angles. So by

Go on to the next page »

the Converse of the Corresponding Angles Postulate, $l \parallel m$.

- C. $\angle 1 \cong \angle 2$ is given. From the diagram, $\angle 1$ and $\angle 2$ are corresponding angles. So by the Corresponding Angles Postulate, $l \parallel m$.
- D. By the Converse of the Corresponding Angles Postulate, $\angle 1 \cong \angle 2$. From the diagram, $l \parallel m$.

ItemID DD-HOLT.1037322
 Correct B
 Standard(s) MA.8-12.G.7.0 (8, 9, 10, 11, 12)

47. Find $m\angle RST$.

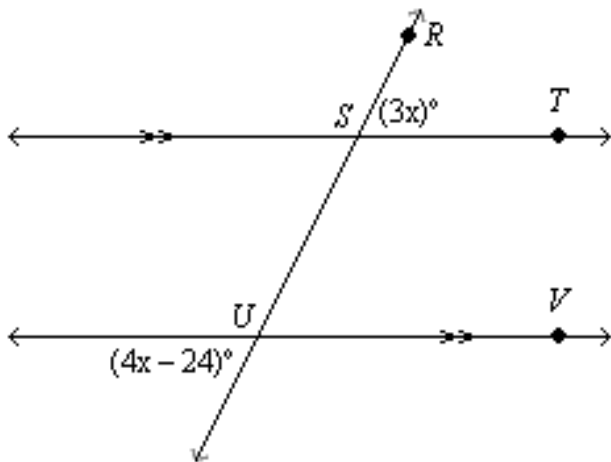

- A. $m\angle RST = 108^\circ$
- B. $m\angle RST = 24^\circ$
- C. $m\angle RST = 156^\circ$
- D. $m\angle RST = 72^\circ$

ItemID DD-HOLT.1037319
 Correct D
 Standard(s) MA.8-12.G.7.0 (8, 9, 10, 11, 12)

48. Use the information $m\angle 1 = (3x + 30)^\circ$, $m\angle 2 = (5x - 10)^\circ$, and $x = 20$

, and the theorems you have learned to show that $l \parallel m$.

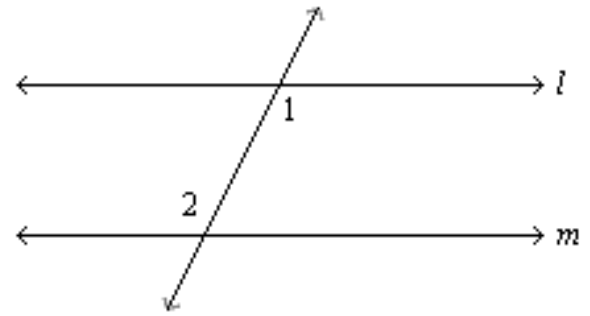

- A. By substitution, $m\angle 1 = 3(20) + 30 = 90^\circ$ and $m\angle 2 = 5(20) - 10 = 90^\circ$. By the Substitution Property of Equality, $m\angle 1 = m\angle 2 = 90^\circ$. By the Converse of the Alternate Interior Angles Theorem, $l \parallel m$.
- B. By substitution, $m\angle 1 = 3(20) + 30 = 90^\circ$ and $m\angle 2 = 5(20) - 10 = 90^\circ$. Since $\angle 1$ and $\angle 2$ are alternate interior angles, $m\angle 1 = m\angle 2 = 180^\circ$. By the Converse of the Same-Side Interior Angles Theorem, $l \parallel m$.
- C. By substitution, $m\angle 1 = 3(20) + 30 = 90^\circ$ and $m\angle 2 = 5(20) - 10 = 90^\circ$. Since $\angle 1$ and $\angle 2$ are same-side interior angles, $m\angle 1 = m\angle 2 = 180^\circ$. By the Converse of the Same-Side Interior Angles Theorem, $l \parallel m$.
- D. Since $\angle 1$ and $\angle 2$ are same-side interior angles, $m\angle 1 = 3(20) + 30 = 90^\circ$ and $m\angle 2 = 5(20) - 10 = 90^\circ$.

Go on to the next page »

By substitution, $m\angle 1 = m\angle 2 = 90^\circ$.
 By the Converse of the Alternate Interior
 Angles Theorem, $l \parallel m$.

ItemID DD-HOLT.1037323
Correct A
Standard(s) MA.8-12.G.7.0 (8, 9, 10, 11, 12)

49. Tom is making a rectangular garden by putting a fence around part of his yard. Tom is using exactly 36 feet of fence. Which of the following widths gives the largest area for the garden?
- A. 6 ft.
 - B. 9 ft.
 - C. 10 ft.
 - D. 11 ft.

ItemID DD.1000848
Correct B
Standard(s) MA.8-12.G.8.0 (8, 9, 10, 11, 12)

50. Juan traced the bottom of a soda can that had a radius of 3.7 cm. What is the circumference of the trace? (use $\pi = 3.14$)
- A. 5.809 cm
 - B. 11.618 cm
 - C. 23.236 cm
 - D. 42.9866 cm

ItemID DD.1000847
Correct C
Standard(s) MA.8-12.G.8.0 (8, 9, 10, 11, 12)

51. Find the area of  in terms of π .

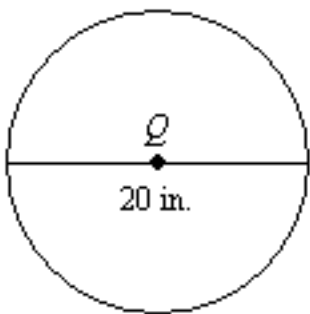

- A. $400 \pi \text{ cm}^2$

- B. 100 cm^2
- C. $200 \pi \text{ cm}^2$
- D. $100 \pi \text{ cm}^2$

ItemID DD-HOLT.1037491
Correct D
Standard(s) MA.8-12.G.8.0 (8, 9, 10, 11, 12)

52. Two circles have the same center. The radius of the larger circle is 3 units longer than the radius of the smaller circle. Find the difference in the circumferences of the two circles. Round to the nearest hundredth.

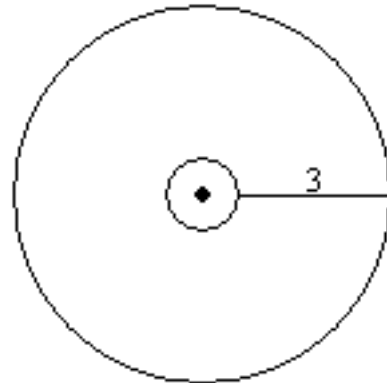

- A. 6.00 units
- B. 18.84 units
- C. 9.42 units
- D. 28.26 units

ItemID DD-HOLT.1037494
Correct B
Standard(s) MA.8-12.G.8.0 (8, 9, 10, 11, 12)

53. A store sells circular rugs in three different sizes. The rugs come in diameters of 8 ft, 12 ft, and 16 ft. Find the areas of the three different sizes of rugs. Use 3.14 for π and round answers to the nearest tenth.
- A. 201.0 ft^2 ; 452.2 ft^2 ; 803.8 ft^2
 - B. 113.0 ft^2 ; 201.0 ft^2 ; 452.4 ft^2
 - C. 50.2 ft^2 ; 113.0 ft^2 ; 201.0 ft^2
 - D. 50.2 ft^2 ; 201.0 ft^2 ; 452.2 ft^2

Go on to the next page »

ItemID DD-HOLT.1037492

Correct C

Standard(s) MA.8-12.G.8.0 (8, 9, 10, 11, 12)

54. Mr. Marlin has a round grass arena on his horse ranch. The arena has a diameter of 50 feet. Mr. Marlin is buying bags of fertilizer that each covers 250 square feet. How many bags of fertilizer does Mr. Marlin need to cover the entire arena?

- A. 1 bag
- B. 7 bags
- C. 8 bags
- D. 31 bags

ItemID DD.1000851

Correct C

Standard(s) MA.8-12.G.8.0 (8, 9, 10, 11, 12)

55. Find the circumference and area of the circle. Use 3.14 for π , and round your answer to the nearest tenth.

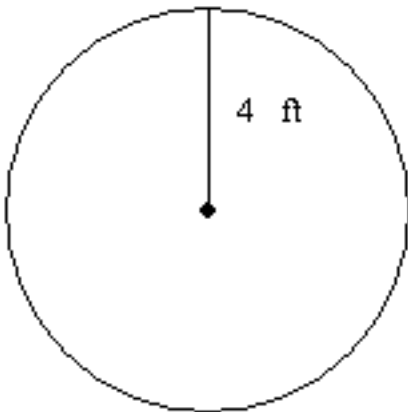

- A. $C = 201.0$ ft; $A = 50.2$ ft²
- B. $C = 50.2$ ft; $A = 25.1$ ft²
- C. $C = 25.1$ ft; $A = 50.2$ ft²
- D. $C = 50.2$ ft; $A = 201.0$ ft²

ItemID DD-HOLT.1037270

Correct C

Standard(s) MA.8-12.G.8.0 (8, 9, 10, 11, 12)

56. Circle P has an area of 36π cm². What is the circumference of circle P ?

- A. 6π cm
- B. 12π cm
- C. 36π cm
- D. 72π cm

ItemID DD.1000839

Correct B

Standard(s) MA.8-12.G.8.0 (8, 9, 10, 11, 12)

57. A home owner wants to make a new deck for his backyard. Redwood costs \$5 per square foot. The units on the graph are in feet. How much will it cost to create the deck shown?

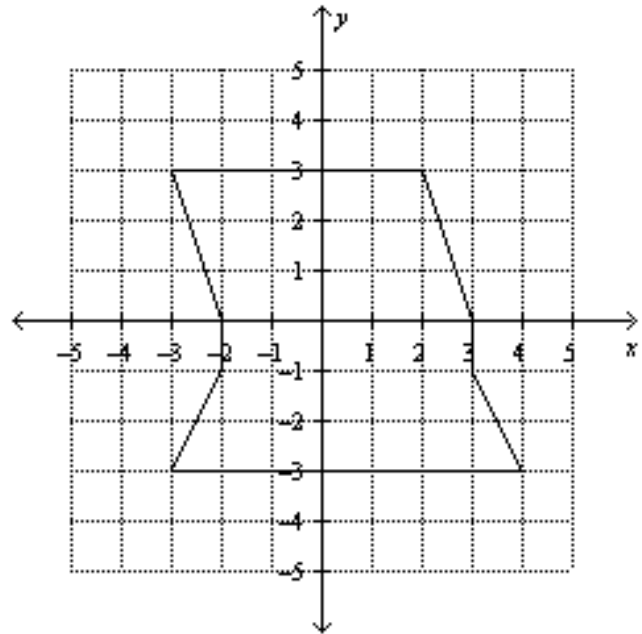

- A. \$160
- B. \$38
- C. \$200
- D. \$190

ItemID DD-HOLT.1037497

Correct A

Standard(s) MA.8-12.G.8.0 (8, 9, 10, 11, 12)

58. Find the shaded area. Round to the nearest tenth.

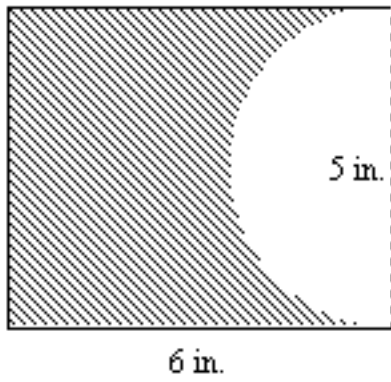

- A. 20.2 in^2
- B. 10.4 in^2
- C. 25.5 in^2
- D. 13.3 in^2

<p>ItemID DD-HOLT.1037496 Correct A Standard(s) MA.8-12.G.8.0 (8, 9, 10, 11, 12)</p>

Stop! You have finished this exam.