

Duality of Light - Electrons

I. To understand electrons, understand light!

II. Light exhibits _____ behavior.

- A. Frequency (____): _____ (units = _____)
- B. Wavelength (____): _____ (units=_____).
- C. At the same speed, the _____, the _____ and the _____ and vice versa.
- D. Since all electromagnetic radiation travels at _____, _____ (c=3.00 x 10⁸ m s⁻¹= speed of light).

III. Light exhibits _____ behavior.

- A. When solids are heated, they glow (_____)!
- B. When you shine a strong enough light on a metal, _____ (_____).
- C. When gases are _____, _____ (spectra)!
- D. Through the above, light acts like a _____ (_____). The energy of photons is given by _____.

- 1. _____, _____
- 2. This assumes that energy is released in _____

E. Photon energy is emitted _____.

IV. Thus, light behaves as _____.

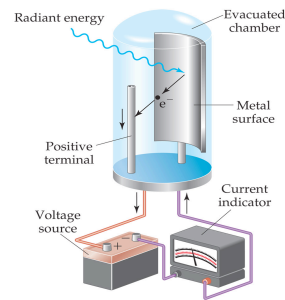
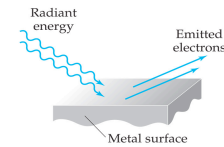

The Bohr Model

I. This paved the way for the Bohr model.

- A. When gases are excited and its light is shined through a prism, _____.
- 1. These _____ needed to be explained.
- 2. Incandescent lightbulbs, when separated into its components, give off a _____.
- 3. When elements are excited, they give off a _____.
- a. This means that only _____.
- b. This light emission is because of _____!

B. Hydrogen, _____, was easy to study.

- 1. Its spectrum led to an equation used to find the _____.
- 2. a.k.a. The Rydberg equation: _____.
- a. _____, _____ (_____)

3. This only works for hydrogen.

C. This gave rise to Bohr's model of circular orbits.

D. Note: If the AP asks for energy change, use _____

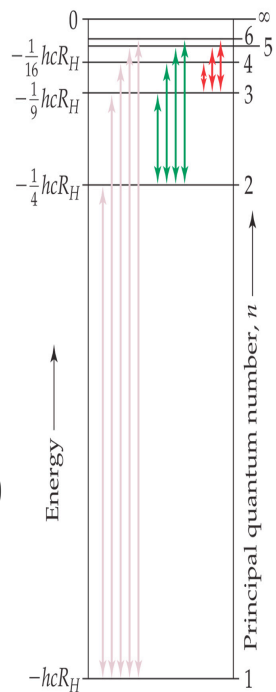

E. Example:

Calculate the energy required to excite the hydrogen electron from level $n=1$ to level $n=2$. Also calculate the wavelength of light that must be absorbed by a hydrogen atom in its ground state to reach its excited state.

Quantum Mechanical Model

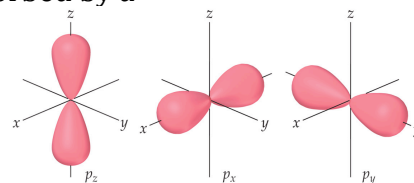

I. Matter also acts like waves. (we're just so big that we can't notice it.)

II. de Broglie related _____ using the following equation:

A. _____, _____
 III. Because matter acts like waves and particles, it is impossible to determine both the _____ and the _____ of an electron (they're _____!)

- A. _____
 B. This gives rise to _____.

IV. Atomic orbitals are shapes in which _____.

V. _____ can be used to describe each orbital.

- A. _____ Quantum Number (____)
 1. _____ (____)
 2. As n goes up, orbital becomes _____, electron is _____.

- B. _____ Quantum Number (____)
 1. _____
 a. for $n=2$, _____
 2. Defines the _____
 a. _____

- C. _____ Quantum Number (____)
 1. Integers from _____
 2. Describes the _____
 3. for $n=2$, _____

- D. _____ Quantum Number (____)
 1. _____ (____)
 2. Describes _____

E. Summarized in Table 6.3

F. _____: _____

G. Must know shape of s, p and d!

VI. Orbitals that _____ are called _____.

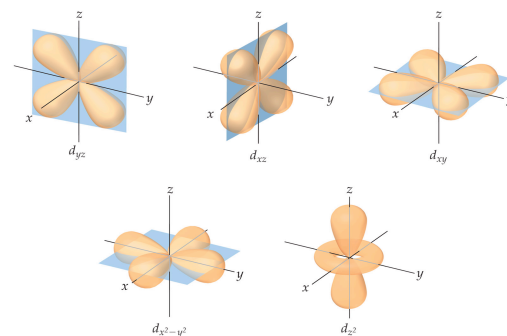
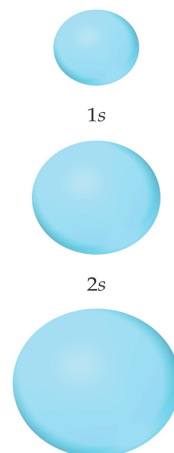

Orbital Diagrams

I. Used to pictorially show how electrons are distributed.

- A. Lines or boxes represent _____
 B. _____ are used to represent electrons. Arrow direction represents _____ (_____)

C. Aufbau Principle: _____

D. Pauli Exclusion Principle: _____

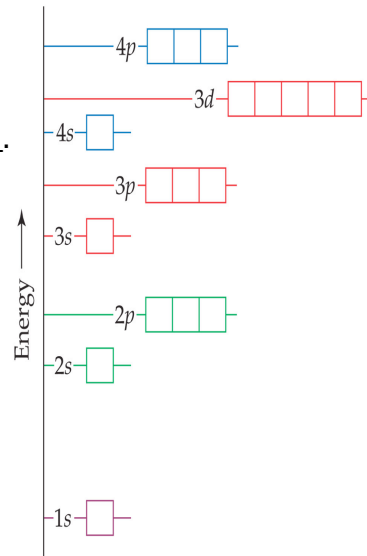

E. Hund's Rule: _____.
 F. FYI, in higher energy levels, _____ are favored.

II. Electron Terms

- A. Paramagnetic:
- B. Diamagnetic:
- C. Isoelectronic:

Electron Configurations

I. This shows how electrons are distributed in the atom.

- A. Use the _____ to do this!
- B. Remember that the d-block is in a _____ (_____) and the f-block is in _____ (_____)

C. Noble gas configuration is a shortcut!

- 1. Use the noble gas _____ then proceed as usual.

II. Transition metal exceptions

- A. Recall _____ and _____ orbitals are _____.
- B. This phenomenon is prevalent in atoms with _____.
- C. Examples:

- 1. Cr (Mo, too): [Ar] 4s²3d⁴ is actually _____
- 2. Cu (Ag, Au too): [Ar] 4s²3d⁹ is actually _____

III. Most s and p block elements become ions that have _____.

- A. Ex. N, O, I, Al, Mg

IV. For transition metals, the _____ because it takes too much energy to pull off all the s and d electrons.

- A. Ex. Mn²⁺ Cu⁺ Cu²⁺ Fe²⁺ Fe³⁺

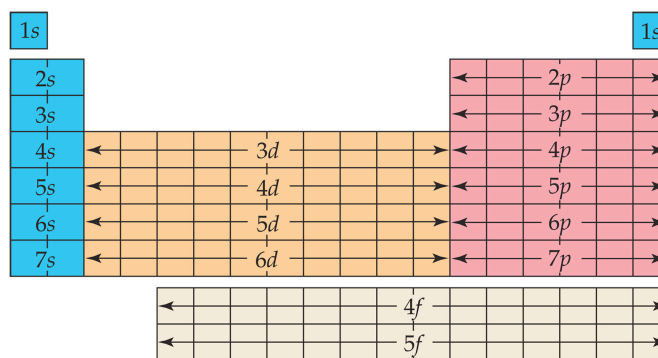

■ Representative s-block elements ■ Representative p-block elements
■ Transition metals ■ f-Block metals

- IV. _____ (_____).
- First _____ - energy required to _____.
 - Second _____ - energy required to _____.
 - It takes more and more energy to _____.
 - After all valence electrons are removed, the _____.
 - From top to bottom, 1st ionization energy _____ because electrons are _____ and are therefore _____.
 - From left to right, 1st ionization energy _____ because _____, resulting in _____, making it _____.
- Two exceptions to this trend:
 - between Groups IIA and IIIA, there is _____ because the _____ (_____).
 - between Groups VA and VIA, there is _____ because the electron removed is from a _____, thus, _____ from the other electron in the suborbital makes it _____.

Element	I_1	I_2	I_3	I_4	I_5	I_6	I_7
Na	495	4562					(inner-shell electrons)
Mg	738	1451	7733				
Al	578	1817	2745	11,577			
Si	786	1577	3232	4356	16,091		
P	1012	1907	2914	4964	6274	21,267	
S	1000	2252	3357	4556	7004	8496	27,107
Cl	1251	2298	3822	5159	6542	9362	11,018
Ar	1521	2666	3931	5771	7238	8781	11,995

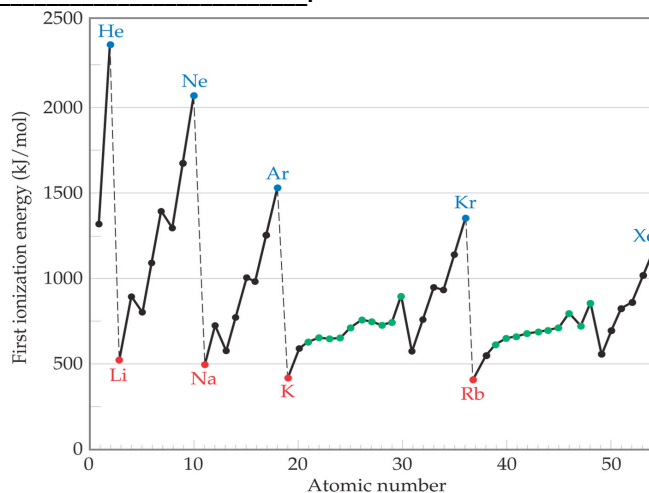

- V. _____:
- Energy change resulting from _____
 - The more negative it is, the _____ (_____).
 - From top to bottom, _____ because the _____ is _____ from the nucleus, therefore feeling _____.
 - From left to right, _____ because atoms are _____ (closer to _____)
- B. Exceptions:
- Group IIA:
 - Added electron must go to _____ (not favorable because _____)
 - electron feels _____ from s electrons
 - Group VA:
 - All orbitals already _____.
 - Extra electron must go _____, causing _____.

H -73						He > 0	
Li -60	Be > 0	B -27	C -122	N > 0	O -141	F -328	Ne > 0
Na -53	Mg > 0	Al -43	Si -134	P -72	S -200	Cl -349	Ar > 0
K -48	Ca -2	Ga -30	Ge -119	As -78	Se -195	Br -325	Kr > 0
Rb -47	Sr -5	In -30	Sn -107	Sb -103	Te -190	I -295	Xe > 0
1A	2A	3A	4A	5A	6A	7A	8A

VI. More reactions!

A. Alkali and Alkali Earth Metals

1. _____ as you go _____. (Alkali Earth are _____)
2. They react with _____ to form _____. (Alkali Earth needs _____)
3. They react with _____ to form _____.
4. They react with _____ to form _____.

C. Halogens

1. _____ as you go _____.
2. Thus, _____, _____, _____.

D. When metals and nonmetals react with water..

1. _____ form _____.
2. _____ form _____ (_____)
3. _____ form _____.