

THE TRIGONOMETRY REPORTING CLUSTER

The following five California content standards are included in the Trigonometry reporting cluster and are represented in this booklet by 23 test questions. These questions represent only some ways in which these standards may be assessed on the Geometry California Mathematics Standards Test.

CALIFORNIA CONTENT STANDARDS IN THIS REPORTING CLUSTER

Geometry

GE18.0* Students know the definitions of the basic trigonometric functions defined by the angles of a right triangle. They also know and are able to use elementary relationships between them. For example, $\tan(\lambda) = \sin(\lambda)/\cos(\lambda)$, $(\sin(\lambda))^2 + (\cos(\lambda))^2 = 1$.

GE19.0* Students use trigonometric functions to solve for an unknown length of a side of a right triangle, given an angle and a length of a side.

GE20.0 Students know and are able to use angle and side relationships in problems with special right triangles, such as 30° , 60° , and 90° triangles and 45° , 45° , and 90° triangles.

GE21.0* Students prove and solve problems regarding relationships among chords, secants, tangents, inscribed angles, and inscribed and circumscribed polygons of circles.

GE22.0* Students know the effect of rigid motions on figures in the coordinate plane and space, including rotations, translations, and reflections.

* Denotes key standards

1 Which of the following best describes deductive reasoning?

- A using logic to draw conclusions based on accepted statements
- B accepting the meaning of a term without definition
- C defining mathematical terms to correspond with physical objects
- D inferring a general truth by examining a number of specific examples

CS00018

2 In the diagram below, $\angle 1 \cong \angle 4$.

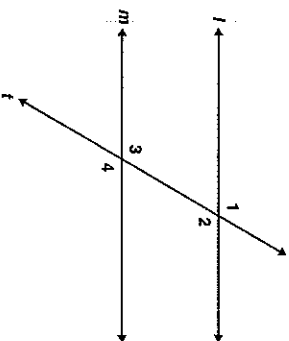

Which of the following conclusions does *not* have to be true?

- A $\angle 3$ and $\angle 4$ are supplementary angles.
- B Line l is parallel to line m .
- C $\angle 1 \cong \angle 3$
- D $\angle 2 \cong \angle 3$

CS00066

3 Consider the arguments below.

- I. Every multiple of 4 is even. 376 is a multiple of 4. Therefore, 376 is even.
- II. A number can be written as a repeating decimal if it is rational. π cannot be written as a repeating decimal. Therefore, π is not rational.

Which one(s), if any, use deductive reasoning?

- A I only
- B II only
- C both I and II
- D neither I nor II

CS00064

4 Theorem: A triangle has at most one obtuse angle.

Eduardo is proving the theorem above by contradiction. He began by assuming that in $\triangle ABC$, $\angle A$ and $\angle B$ are both obtuse. Which theorem will Eduardo use to reach a contradiction?

- A If two angles of a triangle are equal, the sides opposite the angles are equal.
- B If two supplementary angles are equal, the angles each measure 90° .
- C The largest angle in a triangle is opposite the longest side.
- D The sum of the measures of the angles of a triangle is 180° .

CS00065

Geometry

Geometry

5 Use the proof to answer the question below.

Given: $\overline{AB} \cong \overline{BC}$; D is the midpoint of \overline{AC}
 Prove: $\triangle ABD \cong \triangle CBD$

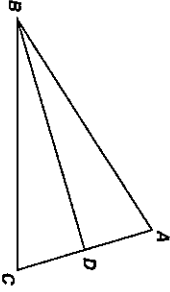

- | Statement | Reason |
|---|---------------------------|
| 1. $\overline{AB} \cong \overline{BC}$; D is the midpoint of \overline{AC} | 1. Given |
| 2. $\overline{AD} \cong \overline{CD}$ | 2. Definition of Midpoint |
| 3. $\overline{BD} \cong \overline{BD}$ | 3. Reflexive Property |
| 4. $\triangle ABD \cong \triangle CBD$ | 4. ? |

What reason can be used to prove that the triangles are congruent?

- A AAS
- B ASA
- C SAS
- D SSS

CONTINUE

6 In the figure below, $AB > BC$.

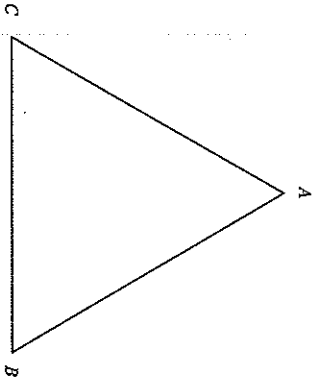

If we assume that $m\angle A = m\angle C$, it follows that $AB = BC$. This contradicts the given statement that $AB > BC$. What conclusion can be drawn from this contradiction?

- A $m\angle A = m\angle B$
- B $m\angle A \neq m\angle B$
- C $m\angle A = m\angle C$
- D $m\angle A \neq m\angle C$

STOP

7 Use the proof to answer the question below.

Given: $\angle 2 \cong \angle 3$
 Prove: $\angle 1 \cong \angle 4$

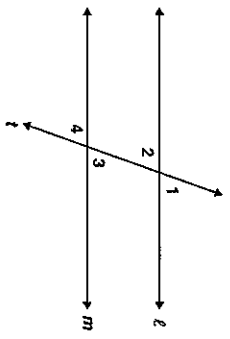

- | Statement | Reason |
|---|------------------------|
| 1. $\angle 2 \cong \angle 3$ | 1. Given |
| 2. $\angle 1 \cong \angle 2; \angle 3 \cong \angle 4$ | 2. ? |
| 3. $\angle 1 \cong \angle 4$ | 3. Transitive Property |

- What reason can be used to justify statement 2?
- A Complements of congruent angles are congruent.
 - B Vertical angles are congruent.
 - C Supplements of congruent angles are congruent.
 - D Corresponding angles are congruent.

CSZ01066

8 "Two lines in a plane always intersect in exactly one point."

Which of the following best describes a counterexample to the assertion above?

- A coplanar lines
- B parallel lines
- C perpendicular lines
- D intersecting lines

CSZ01065

9 Which figure can serve as a counterexample to the conjecture below?

If one pair of opposite sides of a quadrilateral is parallel, then the quadrilateral is a parallelogram.

- A rectangle
- B rhombus
- C square
- D trapezoid

CSZ01064

10 Given: \overline{TRAP} is an isosceles trapezoid with diagonals \overline{RP} and \overline{TA} . Which of the following must be true?

- A $\overline{RP} \perp \overline{TA}$
- B $\overline{RP} \parallel \overline{TA}$
- C $\overline{RP} \cong \overline{TA}$
- D \overline{RP} bisects \overline{TA}

CSZ01060

11 A conditional statement is shown below.

If a quadrilateral has perpendicular diagonals, then it is a rhombus.

Which of the following is a counterexample to the statement above?

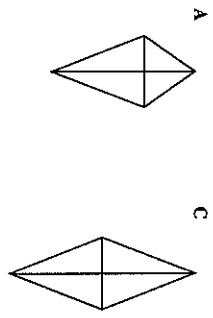

CSZ01068

- 12 Students in a class rewrote theorems in their own words. One student wrote the following statement.

The area of a parallelogram is the product of any base (b) and any height (h).

Which figure shows a counterexample to prove the statement *false*?

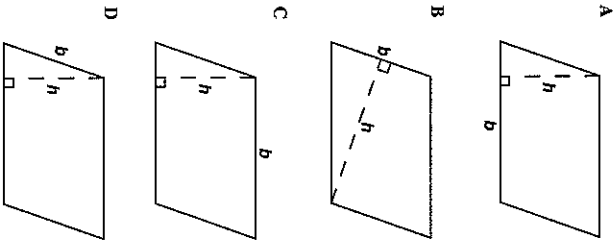

CS00092

- 13 Which triangles must be similar?

- A two obtuse triangles
- B two scalene triangles with congruent bases
- C two right triangles
- D two isosceles triangles with congruent vertex angles

CS00078

- 14 Which of the following facts would be sufficient to prove that triangles ABC and DBE are similar?

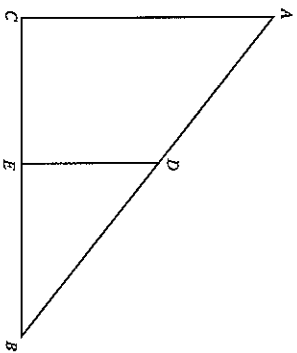

- A \overline{CE} and \overline{BE} are congruent.
- B $\angle ACE$ is a right angle.
- C \overline{AC} and \overline{DE} are parallel.
- D $\angle A$ and $\angle B$ are congruent.

CS00154

- 15 Parallelogram $ABCD$ is shown below.

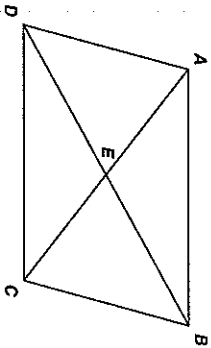

Which pair of triangles can be established to be congruent to prove that $\angle DAB \cong \angle BCD$?

- A $\triangle ADC$ and $\triangle BCD$
- B $\triangle AED$ and $\triangle BEC$
- C $\triangle DAB$ and $\triangle BCD$
- D $\triangle DEC$ and $\triangle BEA$

CS00116

- 16

If $\triangle ABC$ and $\triangle XYZ$ are two triangles such that $\frac{AB}{XY} = \frac{BC}{YZ}$, which of the following would be sufficient to prove the triangles are similar?

- A $\angle A \cong \angle X$
- B $\angle B \cong \angle Y$
- C $\angle C \cong \angle Z$
- D $\angle X \cong \angle Y$

CS00115

- 17 In parallelogram $FGHI$, diagonals \overline{IG} and \overline{FH} are drawn and intersect at point M . Which of the following statements *must* be true?

- A $\triangle FGI$ must be an obtuse triangle.
- B $\triangle HIG$ must be an acute triangle.
- C $\triangle FMG$ must be congruent to $\triangle HMG$.
- D $\triangle GMH$ must be congruent to $\triangle IMF$.

CS00059

- 18 Which of the following *best* describes the triangles shown below?

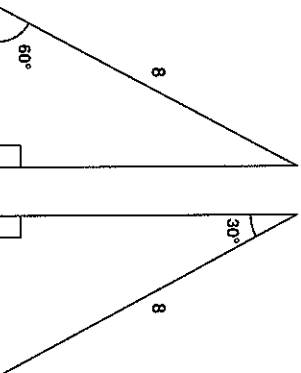

- A both similar and congruent
- B similar but not congruent
- C congruent but not similar
- D neither similar nor congruent

CS00075

Geometry

Geometry

Geometry

- 19 Which of the following statements must be true if $\triangle GHI \sim \triangle JKL$?

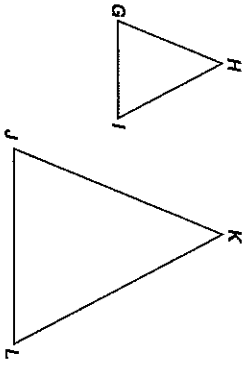

- A The two triangles must be scalene.
- B The two triangles must have exactly one acute angle.
- C At least one of the sides of the two triangles must be parallel.
- D The corresponding sides of the two triangles must be proportional.

CA00094

- 21 In the figure below, $\overline{AC} \cong \overline{DF}$ and $\angle A \cong \angle D$.

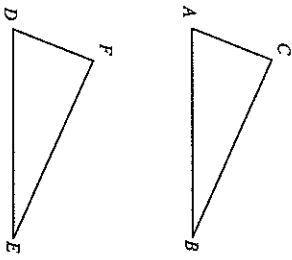

Which additional information would be enough to prove that $\triangle ABC \cong \triangle DEF$?

- A $\overline{AB} \cong \overline{DE}$
- B $\overline{AB} \cong \overline{BC}$
- C $\overline{BC} \cong \overline{EF}$
- D $\overline{BC} \cong \overline{DE}$

CA00017

- 22 Given: \overline{AB} and \overline{CD} intersect at point E .
 $\angle 1 \cong \angle 2$

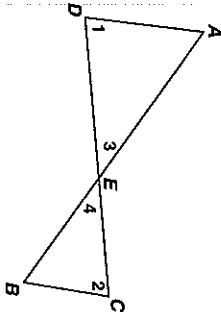

Which theorem or postulate can be used to prove $\triangle AED \sim \triangle BEC$?

- A AA
- B SSS
- C ASA
- D SAS

CA00094

- 23 Given: E is the midpoint of \overline{CD} ; $\angle C \cong \angle D$

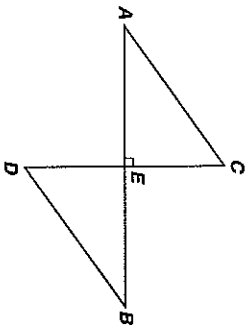

Which of the following statements must be true?

- A $\angle A \cong \angle D$
- B $\angle B \cong \angle C$
- C $\overline{CE} \cong \overline{BE}$
- D $\overline{AC} \cong \overline{BD}$

CA00094

- 20 Which method listed below could *not* be used to prove that two triangles are congruent?

- A Prove all three sets of corresponding sides congruent.
- B Prove all three sets of corresponding angles congruent.
- C Prove that two sides and an included angle of one triangle are congruent to two sides and an included angle of the other triangle.
- D Prove that two angles and an included side of one triangle are congruent to two angles and an included side of the other triangle.

CA00011

- 24 In the figure below, n is a whole number. What is the *smallest* possible value for n ?

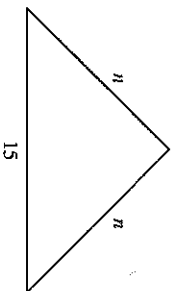

- A 1
- B 7
- C 8
- D 14

CA00095

Geometry

Geometry

Released Test Questions

- 25 Which of the following sets of numbers could represent the lengths of the sides of a triangle?
- A 2, 2, 5
 - B 3, 3, 5
 - C 4, 4, 8
 - D 5, 5, 15

CS01061

- 26 In the accompanying diagram, parallel lines l and m are cut by transversal t .

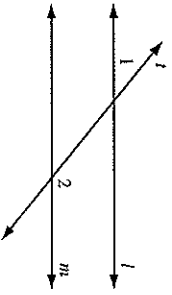

- Which statement about angles 1 and 2 must be true?
- A $\angle 1 \cong \angle 2$.
 - B $\angle 1$ is the complement of $\angle 2$.
 - C $\angle 1$ is the supplement of $\angle 2$.
 - D $\angle 1$ and $\angle 2$ are right angles.

CS04019

- 27 What values of a and b make quadrilateral $MNOP$ a parallelogram?

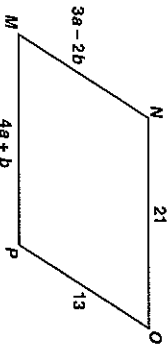

- A $a = 1, b = 5$
- B $a = 5, b = 1$
- C $a = \frac{11}{7}, b = \frac{34}{7}$
- D $a = \frac{34}{7}, b = \frac{11}{7}$

CS01063

- 28 Quadrilateral $ABCD$ is a parallelogram. If adjacent angles are congruent, which statement must be true?

- A Quadrilateral $ABCD$ is a square.
- B Quadrilateral $ABCD$ is a rhombus.
- C Quadrilateral $ABCD$ is a rectangle.
- D Quadrilateral $ABCD$ is an isosceles trapezoid.

CS02068

- 29 For the quadrilateral shown below, what is $m\angle a + m\angle c$?

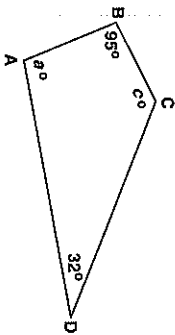

- A 53°
- B 137°
- C 180°
- D 233°

CS02062

- 30 If $ABCD$ is a parallelogram, what is the length of segment BD ?

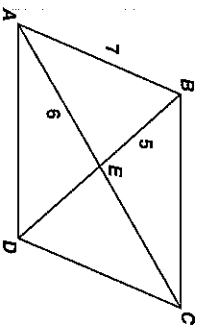

- A 10
- B 11
- C 12
- D 14

CS02065

- 31 The diameter of a circle is 12 meters. If point P is in the same plane as the circle, and is 6 meters from the center of the circle, which best describes the location of point P ?

- A Point P must be on the circle.
- B Point P must be inside the circle.
- C Point P may be either outside the circle or on the circle.
- D Point P may be either inside the circle or on the circle.

CS02067

- 32 Given: $p \parallel q$
 $m \parallel n$
 $m\angle 1 = 75^\circ$

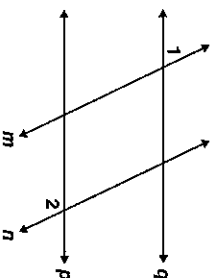

- What is $m\angle 2$?
- A 15°
 - B 75°
 - C 90°
 - D 105°

CS02061

Geometry

- 33 A right circular cone has radius 5 inches and height 8 inches.

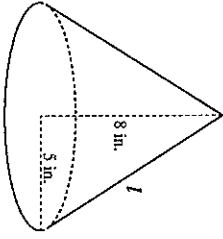

- What is the lateral area of the cone? (Lateral area of cone = πrl , where l = slant height)
- A 40π sq in.
 - B 445π sq in.
 - C $5\pi\sqrt{39}$ sq in.
 - D $5\pi\sqrt{89}$ sq in.

CS00003

- 34 Figure ABCD is a kite.

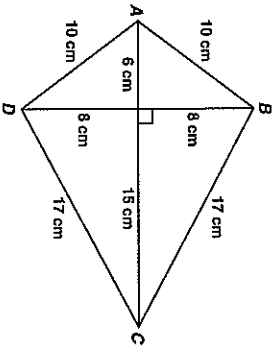

- What is the area of figure ABCD, in square centimeters?
- A 120
 - B 154
 - C 168
 - D 336

CS00017

- 35 If a cylindrical barrel measures 22 inches in diameter, how many inches will it roll in 8 revolutions along a smooth surface?

- A 121π in.
- B 168π in.
- C 176π in.
- D 228π in.

CS00064

Geometry

- 36 A sewing club is making a quilt consisting of 25 squares with each side of the square measuring 30 centimeters. If the quilt has five rows and five columns, what is the perimeter of the quilt?

- A 150 cm
- B 300 cm
- C 600 cm
- D 900 cm

CS00011

- 37 The minute hand of a clock is 5 inches long. What is the area of the circle, in square inches, created as the hand sweeps an hour?

- A 10π
- B 20π
- C 25π
- D 100π

CS00024

- 38 The four sides of this figure will be folded up and taped to make an open box.

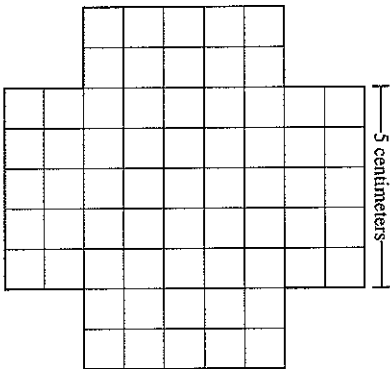

- What will be the volume of the box?
- A 50 cm^3
 - B 75 cm^3
 - C 100 cm^3
 - D 125 cm^3

CS00039

39 A classroom globe has a diameter of 18 inches.

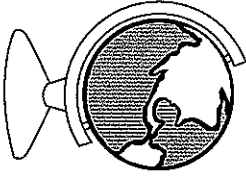

Which of the following is the approximate surface area, in square inches, of the globe? (Surface Area = $4\pi r^2$)

- A 113.0
- B 226.1
- C 254.3
- D 1017.4

CS00004

41 The rectangle shown below has length 20 meters and width 10 meters.

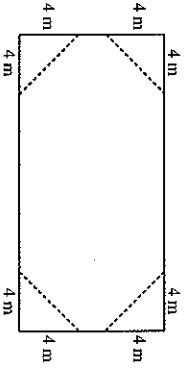

If four triangles are removed from the rectangle as shown, what will be the area of the remaining figure?

- A 136 m^2
- B 144 m^2
- C 168 m^2
- D 184 m^2

CS00012

42 If $RSTW$ is a rhombus, what is the area of $\triangle WX'T'$?

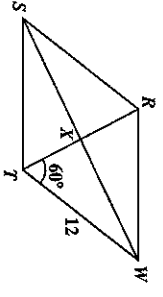

- A $18\sqrt{3}$
- B $36\sqrt{3}$
- C 36
- D 48

CS00017

43 What is the area, in square units, of the trapezoid shown below?

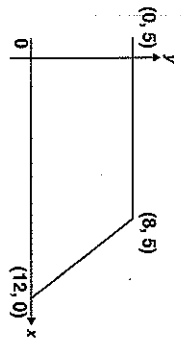

- A 37.5
- B 42.5
- C 50
- D 100

CS00035

44 The figure below is a square with four congruent parallelograms inside.

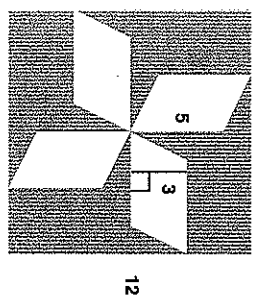

What is the area, in square units, of the shaded portion?

- A 60
- B 84
- C 114
- D 129

CS00036

45 What is the area, in square meters (m²), of the trapezoid shown below?

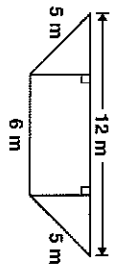

- A 28
- B 36
- C 48
- D 72

CS00047

46 What is the area, in square inches (in²), of the triangle below?

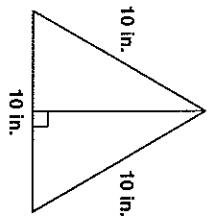

- A 25
- B $25\sqrt{3}$
- C 50
- D $50\sqrt{3}$

CS00048

- 47 What is the area, in square centimeters, of rhombus $RSTV$ if $RT = 16$ cm and $SV = 12$ cm?

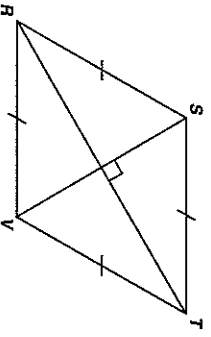

- A 40
B 48
C 96
D 192

CS02014

- 48 The perimeters of two squares are in a ratio of 4 to 9. What is the ratio between the areas of the two squares?

- A 2 to 3
B 4 to 9
C 16 to 27
D 16 to 81

CS02011

- 49 Lee made two candles in the shape of right rectangular prisms. The first candle is 15 cm high, 8 cm long, and 8 cm wide. The second candle is 5 cm higher but has the same length and width. How much additional wax was needed to make the taller candle?

- A 320 cm^3
B 640 cm^3
C 960 cm^3
D 1280 cm^3

CS02016

- 50 Two angles of a triangle have measures of 55° and 65° . Which of the following could *not* be a measure of an exterior angle of the triangle?

- A 115°
B 120°
C 125°
D 130°

CS02071

- 51 The sum of the interior angles of a polygon is the same as the sum of its exterior angles. What type of polygon is it?

- A quadrilateral
B hexagon
C octagon
D decagon

CS02018

- 52 What is $m\angle x$?

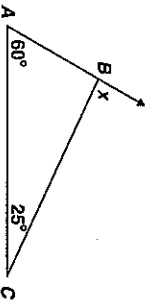

- A 35°
B 60°
C 85°
D 95°

CS02026

- 53 If the measure of an exterior angle of a regular polygon is 120° , how many sides does the polygon have?

- A 3
B 4
C 5
D 6

CS02024

- 54 In the figure below, $\overline{AB} \parallel \overline{CD}$.

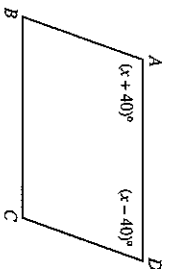

What is the value of x ?

- A 40
B 50
C 80
D 90

CS02014

- 55 The measures of the interior angles of a pentagon are $2x$, $6x$, $4x - 6$, $2x - 16$, and $6x + 2$. What is the measure, in degrees, of the largest angle?

- A 28
B 106
C 170
D 174

CS02024

- 56 A regular polygon has 12 sides. What is the measure of each exterior angle?

- A 15°
- B 30°
- C 45°
- D 60°

CS07009

- 57 What is $m\angle 1$?

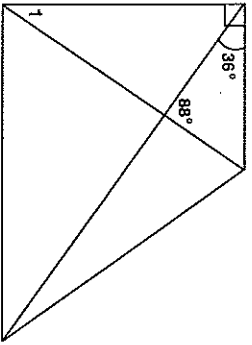

- A 34°
- B 56°
- C 64°
- D 92°

CS03079

- 58 What is $m\angle WZX$?

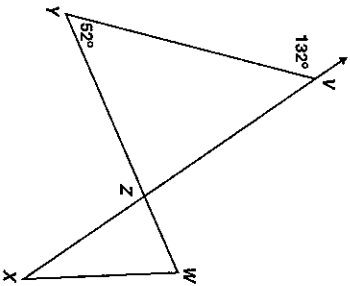

- A 80°
- B 90°
- C 100°
- D 110°

CS03002

- 59 What is the measure of an exterior angle of a regular hexagon?

- A 30°
- B 60°
- C 120°
- D 180°

CS06070

- 60 A diagram from a proof of the Pythagorean theorem is pictured below.

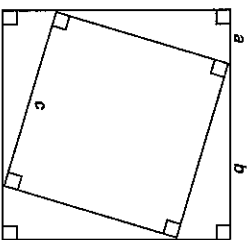

- Which statement would *not* be used in the proof of the Pythagorean theorem?
- A The area of a triangle equals $\frac{1}{2}ab$.
 - B The four right triangles are congruent.
 - C The area of the inner square is equal to half of the area of the larger square.
 - D The area of the larger square is equal to the sum of the areas of the smaller square and the four congruent triangles.

CS01079

- 61 A right triangle's hypotenuse has length 5. If one leg has length 2, what is the length of the other leg?

- A 3
- B $\sqrt{21}$
- C $\sqrt{29}$
- D 7

CS06069

- 62 A new pipeline is being constructed to re-route its oil flow around the exterior of a national wildlife preserve. The plan showing the old pipeline and the new route is shown below.

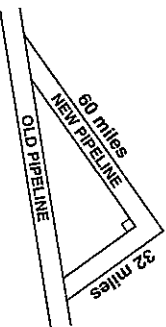

- About how many extra miles will the oil flow once the new route is established?
- A 24
 - B 68
 - C 92
 - D 160

CS01076

Geometry

Geometry

Released Test Questions

63 What is the height of this rectangle?

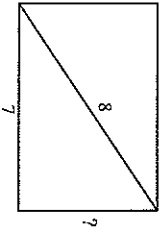

- A 1 unit
- B 6 units
- C $\sqrt{15}$ units
- D $\sqrt{113}$ units

CS00263

65 Given: angle A

What is the first step in constructing the angle bisector of angle A ?

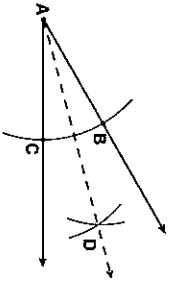

- A Draw ray \overline{AD} .
- B Draw a line segment connecting points B and C .
- C From points B and C , draw equal arcs that intersect at D .
- D From point A , draw an arc that intersects the sides of the angle at points B and C .

CS00214

66 Scott is constructing a line perpendicular to line l from point P . Which of the following should be his first step?

- A
- B
- C
- D

CS00264

67 Which triangle can be constructed using the following steps?

1. Put the tip of the compass on point A .
2. Open the compass so that the pencil tip is on point B .
3. Draw an arc above \overline{AB} .
4. Without changing the opening, put the metal tip on point B and draw an arc intersecting the first arc at point C .
5. Draw \overline{AC} and \overline{BC} .

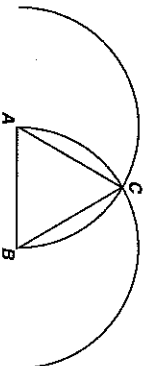

- A right
- B obtuse
- C scalene
- D equilateral

CS00265

64 Marsha is using a straightedge and compass to do the construction shown below.

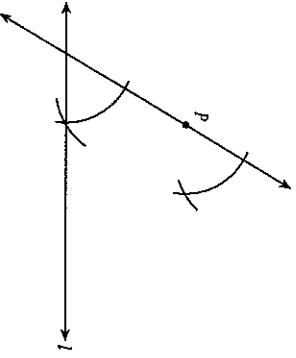

Which best describes the construction Marsha is doing?

- A a line through P parallel to line l
- B a line through P intersecting line l
- C a line through P congruent to line l
- D a line through P perpendicular to line l

CS00213

66 Scott is constructing a line perpendicular to line l from point P . Which of the following should be his first step?

- A
- B
- C
- D

CS00264

67 Which triangle can be constructed using the following steps?

1. Put the tip of the compass on point A .
2. Open the compass so that the pencil tip is on point B .
3. Draw an arc above \overline{AB} .
4. Without changing the opening, put the metal tip on point B and draw an arc intersecting the first arc at point C .
5. Draw \overline{AC} and \overline{BC} .

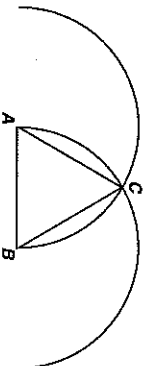

- A right
- B obtuse
- C scalene
- D equilateral

CS00265

68 What geometric construction is shown in the diagram below?

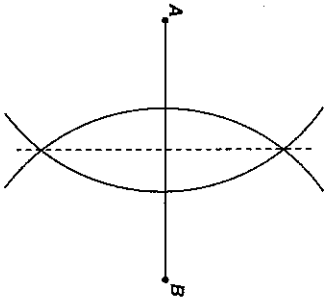

- A an angle bisector
- B a line parallel to a given line
- C an angle congruent to a given angle
- D a perpendicular bisector of a segment

CA00009

69 The diagram shows $\triangle ABC$.

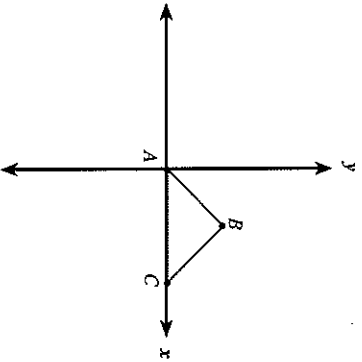

Which statement would prove that $\triangle ABC$ is a right triangle?

- A $(\text{slope } \overline{AB})(\text{slope } \overline{BC}) = 1$
- B $(\text{slope } \overline{AB})(\text{slope } \overline{BC}) = -1$
- C distance from A to B = distance from B to C
- D distance from A to B = (distance from B to C) to C

CA00013

70 Figure $ABCO$ is a parallelogram.

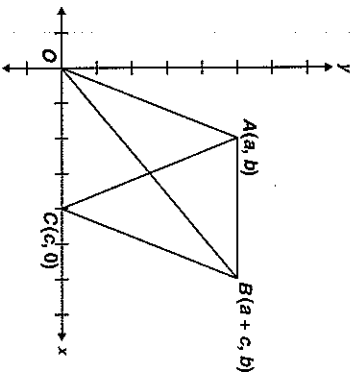

What are the coordinates of the point of intersection of the diagonals?

- A $(\frac{a}{2}, \frac{b}{2})$
- B $(\frac{c}{2}, \frac{b}{2})$
- C $(\frac{a+c}{2}, \frac{b}{2})$
- D $(\frac{a+c}{2}, \frac{a+b}{2})$

CA00010

71 What type of triangle is formed by the points $A(4, 2)$, $B(6, -1)$, and $C(-1, 3)$?

- A right
- B equilateral
- C isosceles
- D scalene

CA00015

72 The point $(-3, 2)$ lies on a circle whose equation is $(x + 3)^2 + (y + 1)^2 = r^2$. Which of the following must be the radius of the circle?

- A 3
- B $\sqrt{10}$
- C 9
- D 10

CA00016

Geometry

73 What is the length of line segment \overline{PQ} shown below?

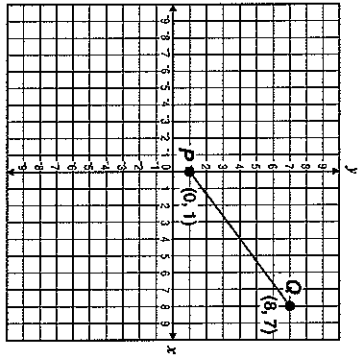

- A 9 units
- B 10 units
- C 13 units
- D 14 units

CS00059

74 In the figure below, if $\sin x = \frac{5}{13}$, what are $\cos x$ and $\tan x$?

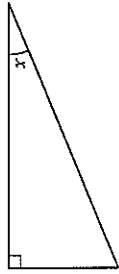

- A $\cos x = \frac{12}{13}$ and $\tan x = \frac{5}{12}$
- B $\cos x = \frac{12}{13}$ and $\tan x = \frac{12}{5}$
- C $\cos x = \frac{13}{12}$ and $\tan x = \frac{5}{12}$
- D $\cos x = \frac{13}{12}$ and $\tan x = \frac{13}{5}$

CS00063

75 In the figure below, $\sin A = 0.7$.

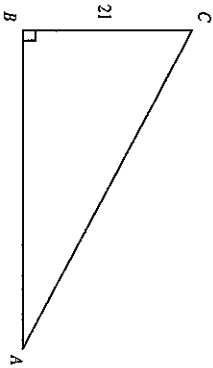

- What is the length of \overline{AC} ?
- A 14.7
 - B 21.7
 - C 30
 - D 32

CS00012

Geometry

76 Approximately how many feet tall is the streetlight?

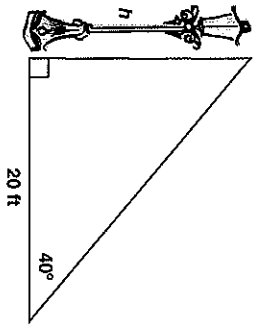

$\sin 40^\circ \approx 0.64$ $\cos 40^\circ \approx 0.77$ $\tan 40^\circ \approx 0.84$
--

- A 12.8
- B 15.4
- C 16.8
- D 23.8

CS00067

77 Right triangle ABC is pictured below.

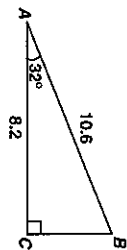

Which equation gives the correct value for BC?

- A $\sin 32^\circ = \frac{BC}{8.2}$
- B $\cos 32^\circ = \frac{BC}{10.6}$
- C $\tan 58^\circ = \frac{8.2}{BC}$
- D $\sin 58^\circ = \frac{BC}{10.6}$

CS00010

Geometry

Geometry

Geometry

- 78** A 13-foot ladder is leaning against a brick wall. The top of the ladder touches the wall 12 feet (ft) above the ground. The bottom of the ladder is 5 ft from the bottom of the wall. What is the sine of the angle formed by the ground and the base of the ladder?

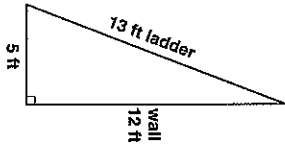

- A $\frac{5}{12}$
 B $\frac{5}{13}$
 C $\frac{12}{13}$
 D $\frac{13}{5}$

CS00941

- 79** In the accompanying diagram, $m\angle A = 32^\circ$ and $AC = 10$. Which equation could be used to find x in $\triangle ABC$?

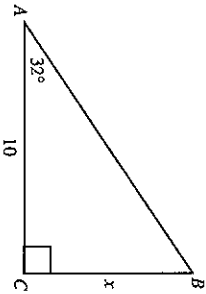

- A $x = 10 \sin 32^\circ$
 B $x = 10 \cos 32^\circ$
 C $x = 10 \tan 32^\circ$
 D $x = \frac{10}{\cos 32^\circ}$

CS00943

- 80** The diagram shows an 8-foot ladder leaning against a wall. The ladder makes a 53° angle with the wall. Which is closest to the distance up the wall the ladder reaches?

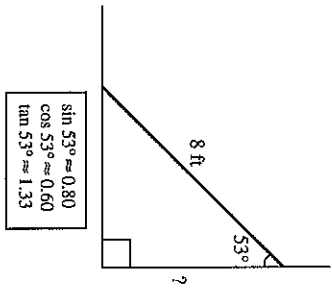

- A 3.2 ft
 B 4.8 ft
 C 6.4 ft
 D 9.6 ft

CS00942

- 81** Triangle JKL is shown below.

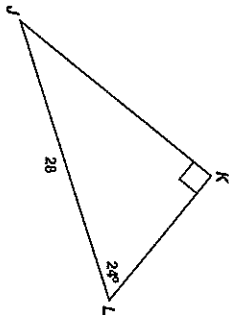

Which equation should be used to find the length of JK ?

- A $\sin 24^\circ = \frac{JK}{28}$
 B $\sin 24^\circ = \frac{28}{JK}$
 C $\cos 24^\circ = \frac{JK}{28}$
 D $\cos 24^\circ = \frac{28}{JK}$

CS00901

Geometry

Geometry

Geometry

82 What is the approximate height, in feet, of the tree in the figure below?

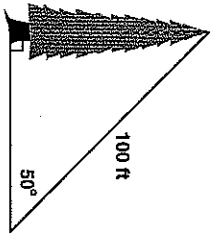

$$\begin{aligned} \sin 50^\circ &\approx 0.766 \\ \cos 50^\circ &\approx 0.643 \\ \tan 50^\circ &\approx 1.192 \end{aligned}$$

- A 64.3
- B 76.6
- C 119.2
- D 130.5

CS000106

83 What is the approximate value of x in the triangle below?

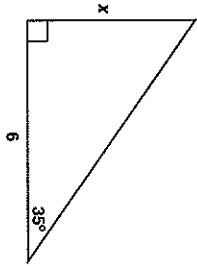

$$\begin{aligned} \sin 35^\circ &\approx 0.57 \\ \cos 35^\circ &\approx 0.82 \\ \tan 35^\circ &\approx 0.7 \end{aligned}$$

- A 3.4 units
- B 4.2 units
- C 4.9 units
- D 7.3 units

CS000106

84 If $a = 3\sqrt{3}$ in the right triangle below, what is the value of b ?

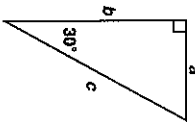

- A 9
- B $6\sqrt{3}$
- C $12\sqrt{3}$
- D 18

CS000106

85 What is the value of x in the triangle below?

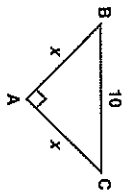

- A 5
- B $5\sqrt{2}$
- C $10\sqrt{3}$
- D 20

CS000106

86 What is the value of x , in inches?

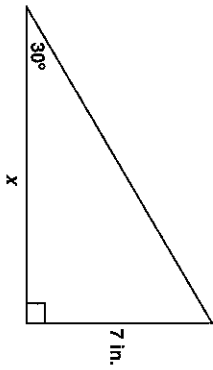

- A $7\sqrt{3}$
- B 14
- C $14\sqrt{3}$
- D 21

ES00098

88 In the circle below, \overline{AB} and \overline{CD} are chords intersecting at E .

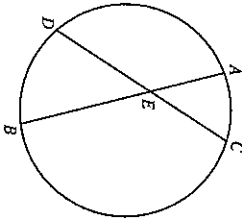

If $AE = 5$, $BE = 12$, and $CE = 6$, what is the length of \overline{DE} ?

- A 7
- B 9
- C 10
- D 13

CS00022

89 \overline{KB} is tangent to a circle, whose center is A , at point B . \overline{BD} is a diameter.

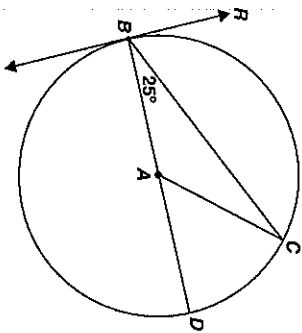

What is $m\angle CBR$?

- A 50°
- B 65°
- C 90°
- D 130°

CS00316

90 In the figure below, \overline{AB} is tangent to circle O at point A , secant \overline{BD} intersects circle O at points C and D , $m\angle C = 70^\circ$, and $m\angle D = 110^\circ$.

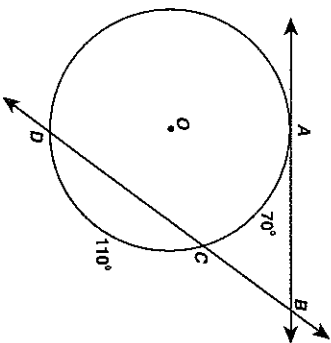

What is $m\angle ABC$?

- A 20°
- B 40°
- C 55°
- D 70°

CS00316

87 A square is circumscribed about a circle. What is the ratio of the area of the circle to the area of the square?

- A $\frac{1}{4}$
- B $\frac{1}{2}$
- C $\frac{2}{\pi}$
- D $\frac{\pi}{4}$

CS00065

- 91 In the circle shown below, the measure of $\widehat{PR} = 140^\circ$ and the measure of $\angle RPQ = 50^\circ$.

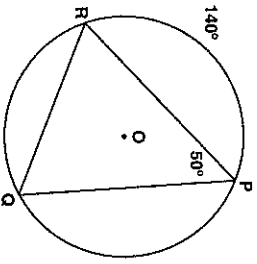

- What is the measure of \widehat{PQ} ?
- A 50°
 - B 60°
 - C 70°
 - D 120°

CS01000

- 92 \overline{QS} is a diameter of the circle below, and $\overline{QS} \perp \overline{PR}$.

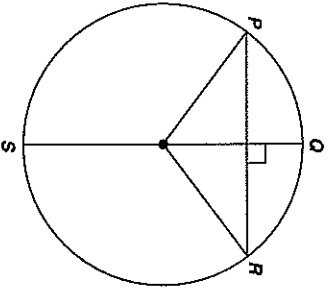

- If $m\widehat{PQR} = 106^\circ$, what is $m\widehat{PS}$?
- A 53°
 - B 74°
 - C 106°
 - D 127°

CS00119

- 93 The vertices of $\triangle ABC$ are $A(2, 1)$, $B(3, 4)$, and $C(1, 3)$. If $\triangle ABC$ is translated 1 unit down and 3 units to the left to create $\triangle DEF$, what are the coordinates of the vertices of $\triangle DEF$?
- A $D(0, 1)$, $E(1, 2)$, $F(1, 3)$
 - B $D(0, -1)$, $E(0, 3)$, $F(-2, -2)$
 - C $D(-2, 2)$, $E(0, 3)$, $F(-1, 0)$
 - D $D(-1, 0)$, $E(0, 3)$, $F(-2, 2)$

CS00017

- 94 If triangle ABC is rotated 180 degrees about the origin, what are the coordinates of A' ?

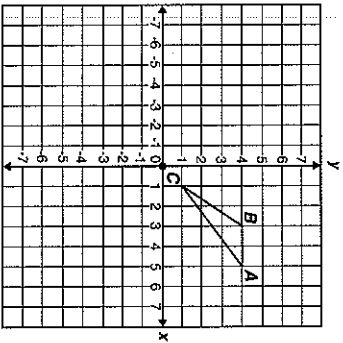

- A $(-5, -4)$
- B $(-5, 4)$
- C $(-4, 5)$
- D $(-4, -5)$

CS00046

- 95 Trapezoid $ABCD$ below is to be translated to trapezoid $A'B'C'D'$ by the following motion rule.

$$(x, y) \rightarrow (x + 3, y - 4)$$

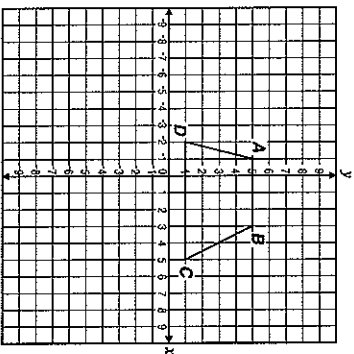

- What will be the coordinates of vertex C' ?
- A $(1, -3)$
 - B $(2, 1)$
 - C $(6, 1)$
 - D $(8, -3)$

CS001014

- 96 Which expression describes the translation of a point from $(-3, 4)$ to $(4, -1)$?
- A 7 units left and 5 units up
 - B 7 units right and 5 units up
 - C 7 units left and 5 units down
 - D 7 units right and 5 units down

CSDE0000

Question Number	Correct Answer	Standard	Year of Release
1	A	GE1.0	2004
2	A	GE1.0	2005
3	C	GE1.0	2007
4	D	GE2.0	2003
5	D	GE2.0	2004
6	D	GE2.0	2005
7	B	GE2.0	2007
8	B	GE3.0	2003
9	D	GE3.0	2004
10	C	GE3.0	2005
11	A	GE3.0	2006
12	D	GE3.0	2008
13	D	GE4.0	2003
14	C	GE4.0	2004
15	C	GE4.0	2005
16	B	GE4.0	2005
17	D	GE4.0	2006
18	A	GE4.0	2007
19	D	GE4.0	2007
20	B	GE4.0	2008
21	A	GE5.0	2003
22	A	GE5.0	2004
23	D	GE5.0	2008
24	C	GE6.0	2003
25	B	GE6.0	2007
26	C	GE7.0	2003
27	B	GE7.0	2004
28	C	GE7.0	2005
29	D	GE7.0	2006
30	A	GE7.0	2006
31	A	GE7.0	2008
32	D	GE7.0	2008
33	D	GE8.0	2003
34	C	GE8.0	2005
35	C	GE8.0	2006